

09_08/2019

PROJECT: 51358

CONTRACT: DK00400

See Sheet 1A For Index of Sheets
See Sheet 1B For Symbology Sheet

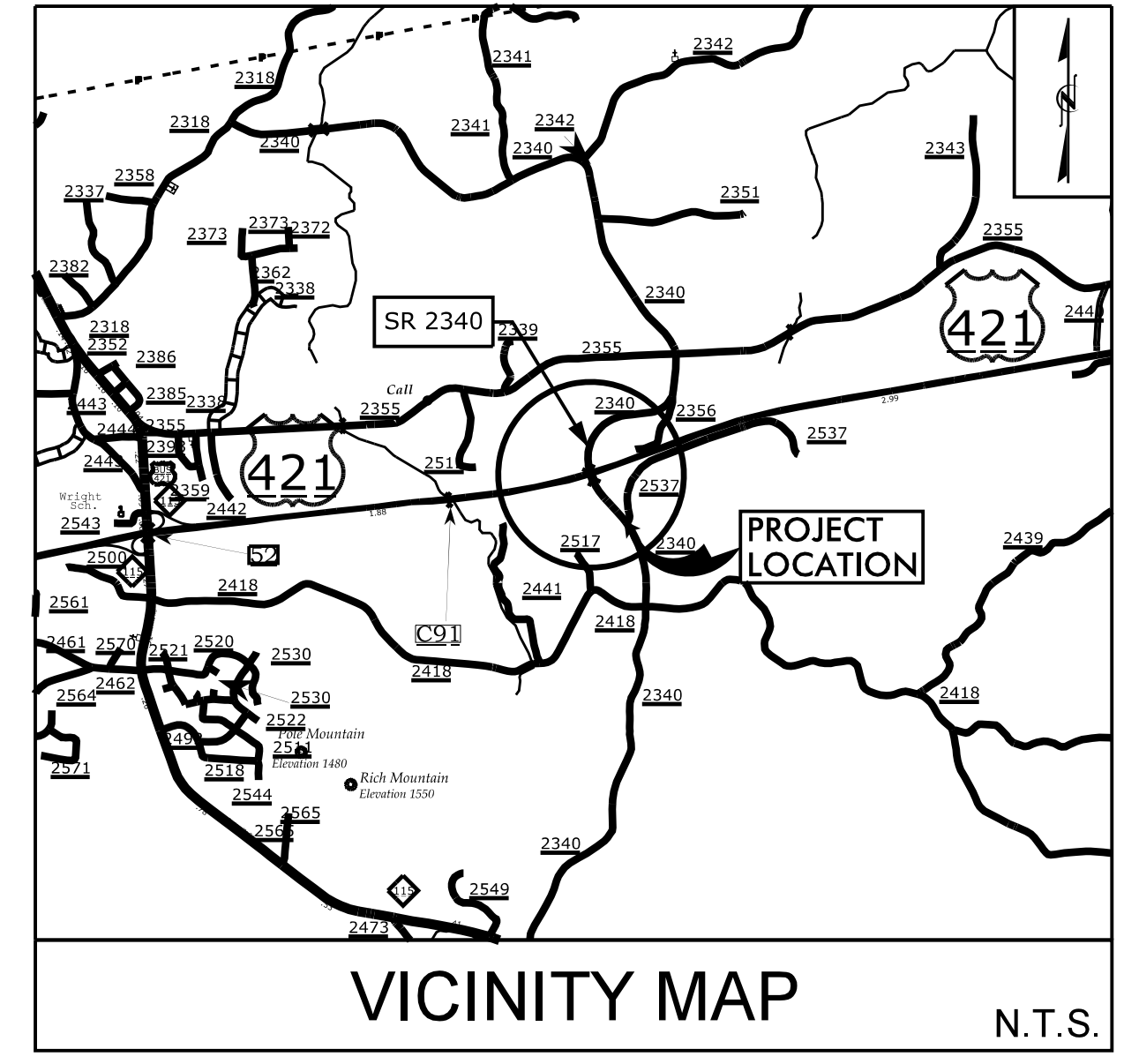

FINAL PLANS

STATE OF NORTH CAROLINA
DIVISION OF HIGHWAYS

WILKES COUNTY

**LOCATION: PEDESTRIAN BRIDGE OVER US 421 AT
NORTH WILKESBORO SPEEDWAY**

TYPE OF WORK: GRADING, DRAINAGE, PAVING & STRUCTURE

STATE	STATE PROJECT REFERENCE NO.	SHEET NO.	TOTAL SHEETS
N.C.	51358	1	29
STATE PROJ. NO.	F.A. PROJ. NO.	DESCRIPTION	
51358	N/A	PE, ROW, CONST	

DIVISION II

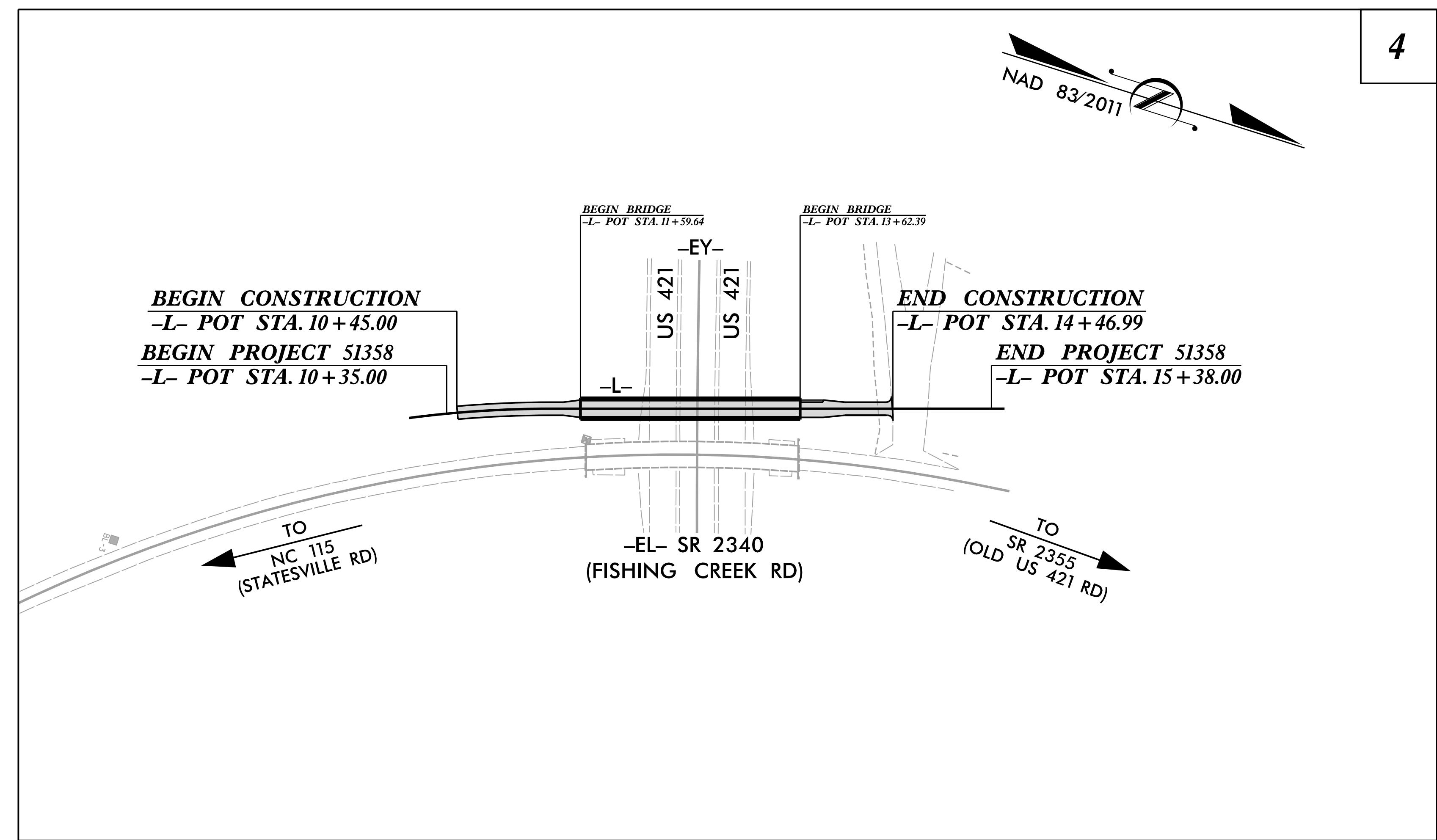
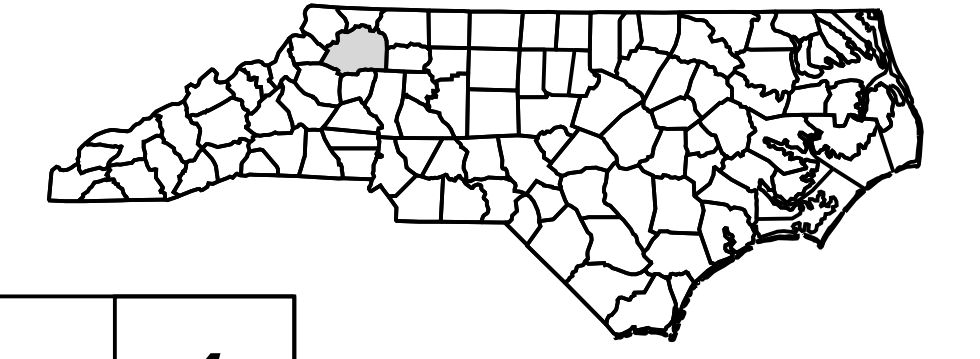

DOCUMENT NOT CONSIDERED FINAL
UNLESS ALL SIGNATURES COMPLETED

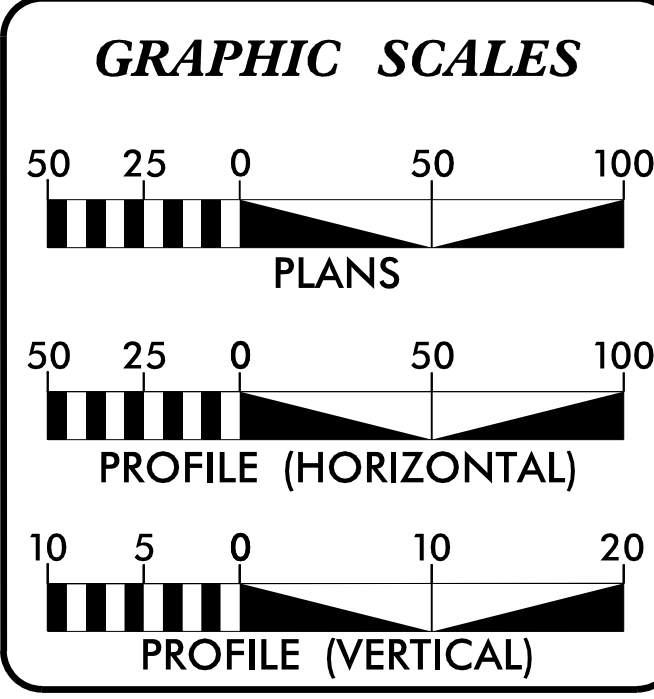

DESIGN DATA
N/A

PROJECT LENGTH

LENGTH ROADWAY PROJECT 51358	=	0.057 MI
LENGTH STRUCTURES PROJECT 51358	=	0.038 MI
TOTAL LENGTH PROJECT 51358	=	0.095 MI

Prepared in the Office of:

One Glenwood Avenue
Suite 900
Raleigh, NC 27603
919-420-7600
NC Lic. No. P-0270

2024 STANDARD SPECIFICATIONS

RIGHT OF WAY DATE:
N/A

LETTING DATE:
AUGUST 15, 2024

RICKY A. TIPTON, PE
PROJECT ENGINEER

JOSEPH R. CONRAD, PE
PROJECT DESIGN ENGINEER

RAMIE A. SHAW, PE
NCDOT CONTACT

HYDRAULICS ENGINEER

DocuSigned by:
7/30/2024
P.E.

SIGNATURE: B25ECD1434EE4AF

ROADWAY DESIGN ENGINEER

DocuSigned by:
Joseph Conrad, P.E.
7/30/2024
P.E.

SIGNATURE: F175BF861DCE4D1...

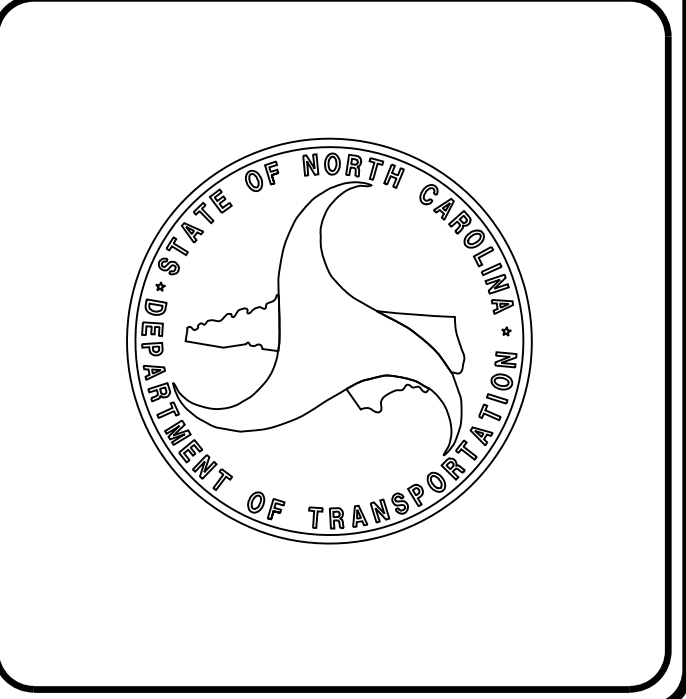

PROJECT REFERENCE NO.	SHEET NO.
51358	1A
RW SHEET NO.	
ROADWAY DESIGN ENGINEER	
	
DOCUMENT NOT CONSIDERED FINAL UNLESS ALL SIGNATURES COMPLETED	

SHEET NUMBER

SHEET DESCRIPTION

1	TITLE SHEET
1A	INDEX OF SHEETS
1B	CONVENTIONAL SYMBOLS
2A-1	PAVEMENT SCHEDULE AND TYPICAL SECTIONS
2C-1	SPECIAL DETAILS
3B-1	EARTHWORK SUMMARY
4	PLAN SHEET
TMP-1 THRU TMP-4	TRANSPORTATION MANAGEMENT PLANS
EC-1 THRU EC-4	EROSION CONTROL PLANS
P-1 THRU P-11	STRUCTURE PLANS
X-1	CROSS SECTION SUMMARY
X-2 THRU X-8	CROSS SECTIONS

STANDARD DRAWINGS

STD.NO.	TITLE
DIVISION 2 – EARTHWORK	
225.02	Guide for Grading Subgrade – Secondary and Local
DIVISION 8 – INCIDENTALS	
846.01	Concrete Curb, Gutter and Curb & Gutter

GENERAL NOTES

GENERAL NOTES: 2024 SPECIFICATIONS
 EFFECTIVE: 01-16-2024
 REVISED:

GRADING:
 THE GRADE LINES SHOWN DENOTE THE FINISHED ELEVATION OF THE PROPOSED OR FUTURE SURFACING AT GRADE POINTS SHOWN ON THE TYPICAL SECTIONS. GRADE LINES MAY BE ADJUSTED AT THEIR BEGINNING AND ENDING AND AT STRUCTURES AS DIRECTED BY THE ENGINEER IN ORDER TO SECURE A PROPER TIE-IN.

CLEARING:
 CLEARING ON THIS PROJECT SHALL BE PERFORMED TO THE LIMITS ESTABLISHED BY METHOD II.

END BENTS:
 THE ENGINEER SHALL CHECK THE STRUCTURE END BENT PLANS, DETAILS, AND CROSS-SECTION PRIOR TO SETTING OF THE SLOPE STAKES FOR THE EMBANKMENT OR EXCAVATION APPROACHING A BRIDGE.

UTILITIES:
 UTILITY OWNERS ON THIS PROJECT ARE DUKE ENERGY & WILKES COMMUNICATION. ANY RELOCATION OF EXISTING UTILITIES WILL BE ACCOMPLISHED BY OTHERS.

RIGHT-OF-WAY MARKERS:
 ALL RIGHT-OF-WAY MARKERS ON THIS PROJECT SHALL BE PLACED BY OTHERS.

STATE OF NORTH CAROLINA, DIVISION OF HIGHWAYS CONVENTIONAL PLAN SHEET SYMBOLS

Note: Not to Scale

BOUNDARIES AND PROPERTY:

State Line	-----
County Line	-----
Township Line	-----
City Line	-----
Reservation Line	-----
Property Line	-----
Existing Iron Pin (EIP)	○
Computed Property Corner	×
Existing Concrete Monument (ECM)	□
Parcel/Sequence Number	(23)
Existing Fence Line	-x-x-x-
Proposed Woven Wire Fence	○
Proposed Chain Link Fence	□
Proposed Barbed Wire Fence	◇
Existing Wetland Boundary	-WLB-
Proposed Wetland Boundary	-WLB-
Existing Endangered Animal Boundary	-EAB-
Existing Endangered Plant Boundary	-EPB-
Existing Historic Property Boundary	-HPB-
Known Contamination Area: Soil	-----
Potential Contamination Area: Soil	-----
Known Contamination Area: Water	-----
Potential Contamination Area: Water	-----
Contaminated Site: Known or Potential	☠ ?

BUILDINGS AND OTHER CULTURE:

Gas Pump Vent or U/G Tank Cap	○
Sign	○
Well	○
Small Mine	×
Foundation	□
Area Outline	□
Cemetery	□
Building	□
School	□
Church	□
Dam	-----

HYDROLOGY:

Stream or Body of Water	-----
Hydro, Pool or Reservoir	-----
Jurisdictional Stream	-JS-
Buffer Zone 1	-BZ 1-
Buffer Zone 2	-BZ 2-
Flow Arrow	←
Disappearing Stream	-----
Spring	○
Wetland	-----
Proposed Lateral, Tail, Head Ditch	-----
False Sump	-----

RAILROADS:

Standard Gauge	-----
RR Signal Milepost	○
Switch	□
RR Abandoned	-----
RR Dismantled	-----

RIGHT OF WAY & PROJECT CONTROL:

Primary Horiz Control Point	○
Primary Horiz and Vert Control Point	●
Secondary Horiz and Vert Control Point	◆
Vertical Benchmark	⊠
Existing Right of Way Monument	△
Proposed Right of Way Monument (Rebar and Cap)	▲
Proposed Right of Way Monument (Concrete)	⊙
Existing Permanent Easement Monument	◇
Proposed Permanent Easement Monument (Rebar and Cap)	◆
Existing C/A Monument	△
Proposed C/A Monument (Rebar and Cap)	▲
Proposed C/A Monument (Concrete)	⊙
Existing Right of Way Line	-----
Proposed Right of Way Line	-----
Existing Control of Access Line	-----
Proposed Control of Access Line	-----
Proposed ROW and CA Line	-----
Existing Easement Line	-----
Proposed Temporary Construction Easement	-----
Proposed Temporary Drainage Easement	-----
Proposed Permanent Drainage Easement	-----
Proposed Permanent Drainage/Utility Easement	-----
Proposed Permanent Utility Easement	-----
Proposed Temporary Utility Easement	-----
Proposed Aerial Utility Easement	-----

ROADS AND RELATED FEATURES:

Existing Edge of Pavement	-----
Existing Curb	-----
Proposed Slope Stakes Cut	-----
Proposed Slope Stakes Fill	-----
Proposed Curb Ramp	-----
Existing Metal Guardrail	-----
Proposed Guardrail	-----
Existing Cable Guiderail	-----
Proposed Cable Guiderail	-----
Equality Symbol	⊕
Pavement Removal	-----
VEGETATION:	
Single Tree	○
Single Shrub	○
Hedge	-----

Woods Line	-----
Orchard	-----
Vineyard	-----

EXISTING STRUCTURES:

MAJOR:	
Bridge, Tunnel or Box Culvert	-----
Bridge Wing Wall, Head Wall and End Wall	-----
MINOR:	
Head and End Wall	-----
Pipe Culvert	-----
Footbridge	-----
Drainage Box: Catch Basin, DI or JB	-----
Paved Ditch Gutter	-----
Storm Sewer Manhole	○
Storm Sewer	-----

UTILITIES:

* SUE - Subsurface Utility Engineering
LOS - Level of Service - A,B,C or D (Accuracy)

POWER:	
Existing Power Pole	●
Proposed Power Pole	○
Existing Joint Use Pole	●
Proposed Joint Use Pole	○
Power Manhole	⊙
Power Line Tower	⊠
Power Transformer	⊠
U/G Power Cable Hand Hole	⊠
H-Frame Pole	●
U/G Power Line Test Hole (SUE - LOS A)*	⊙
U/G Power Line (SUE - LOS B)*	-----
U/G Power Line (SUE - LOS C)*	-----
U/G Power Line (SUE - LOS D)*	-----

TELEPHONE:

Existing Telephone Pole	●
Proposed Telephone Pole	○
Telephone Manhole	⊙
Telephone Pedestal	⊠
Telephone Cell Tower	⊠
U/G Telephone Cable Hand Hole	⊠
U/G Telephone Test Hole (SUE - LOS A)*	⊙
U/G Telephone Cable (SUE - LOS B)*	-----
U/G Telephone Cable (SUE - LOS C)*	-----
U/G Telephone Cable (SUE - LOS D)*	-----
U/G Telephone Conduit (SUE - LOS B)*	-----
U/G Telephone Conduit (SUE - LOS C)*	-----
U/G Telephone Conduit (SUE - LOS D)*	-----
U/G Fiber Optics Cable (SUE - LOS B)*	-----
U/G Fiber Optics Cable (SUE - LOS C)*	-----
U/G Fiber Optics Cable (SUE - LOS D)*	-----

WATER:

Water Manhole	⊙
Water Meter	○
Water Valve	⊗
Water Hydrant	⊕
U/G Water Line Test Hole (SUE - LOS A)*	⊙
U/G Water Line (SUE - LOS B)*	-----
U/G Water Line (SUE - LOS C)*	-----
U/G Water Line (SUE - LOS D)*	-----
Above Ground Water Line	-----

TV:

TV Pedestal	⊠
TV Tower	⊗
U/G TV Cable Hand Hole	⊠
U/G TV Test Hole (SUE - LOS A)*	⊙
U/G TV Cable (SUE - LOS B)*	-----
U/G TV Cable (SUE - LOS C)*	-----
U/G TV Cable (SUE - LOS D)*	-----
U/G Fiber Optic Cable (SUE - LOS B)*	-----
U/G Fiber Optic Cable (SUE - LOS C)*	-----
U/G Fiber Optic Cable (SUE - LOS D)*	-----

GAS:

Gas Valve	◇
Gas Meter	⊕
U/G Gas Line Test Hole (SUE - LOS A)*	⊙
U/G Gas Line (SUE - LOS B)*	-----
U/G Gas Line (SUE - LOS C)*	-----
U/G Gas Line (SUE - LOS D)*	-----
Above Ground Gas Line	-----

SANITARY SEWER:

Sanitary Sewer Manhole	⊙
Sanitary Sewer Cleanout	⊕
U/G Sanitary Sewer Line	-----
Above Ground Sanitary Sewer	-----
SS Force Main Line Test Hole (SUE - LOS A)*	⊙
SS Force Main Line (SUE - LOS B)*	-----
SS Force Main Line (SUE - LOS C)*	-----
SS Force Main Line (SUE - LOS D)*	-----

MISCELLANEOUS:

Utility Pole	●
Utility Pole with Base	⊠
Utility Located Object	○
Utility Traffic Signal Box	⊠
Utility Unknown U/G Line (SUE - LOS B)*	-----
U/G Tank; Water, Gas, Oil	-----
Underground Storage Tank, Approx. Loc.	-----
A/G Tank; Water, Gas, Oil	-----
Geoenvironmental Boring	⊕
Abandoned According to Utility Records	-----
End of Information	-----

PROJECT REFERENCE NO. 51358	SHEET NO. 2A-1
RW SHEET NO.	
ROADWAY DESIGN ENGINEER	
DOCUMENT NOT CONSIDERED FINAL UNLESS ALL SIGNATURES COMPLETED	

PAVEMENT SCHEDULE	
C1	PROP. APPROX 2" ASPHALT CONCRETE SURFACE COURSE, TYPE S9.5B, AT AN AVERAGE RATE OF 110 LBS. PER SQ. YARD IN EACH OF TWO LAYERS.
J1	PROP. 6" AGGREGATE BASE COURSE
P	PRIME COAT
R	2'-6" CURB & GUTTER
T	EARTH MATERIAL

ALL PAVEMENT SLOPES ARE 1:1 UNLESS OTHERWISE SHOWN

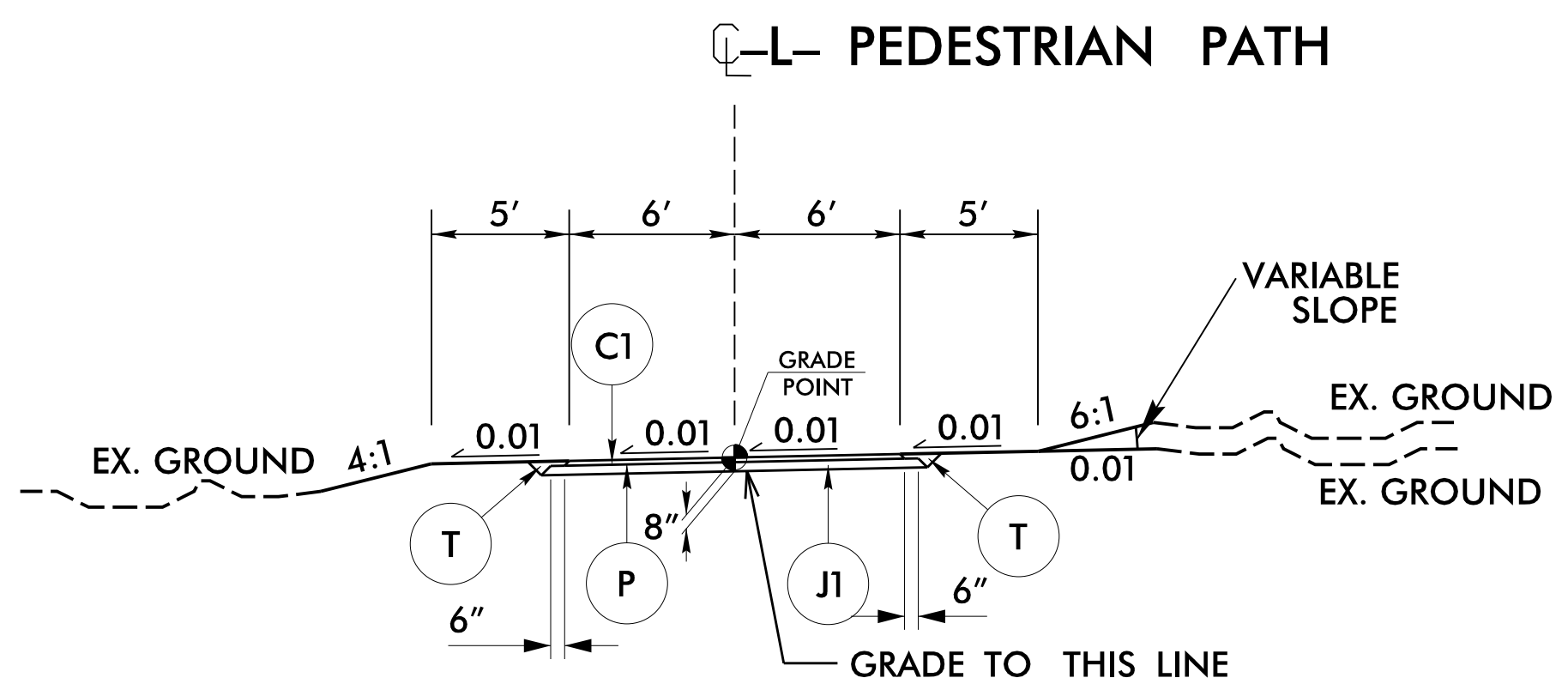

TYPICAL SECTION 1

-L- STA. 10+45.00 TO STA. 11+59.64 (BEGIN BRIDGE)

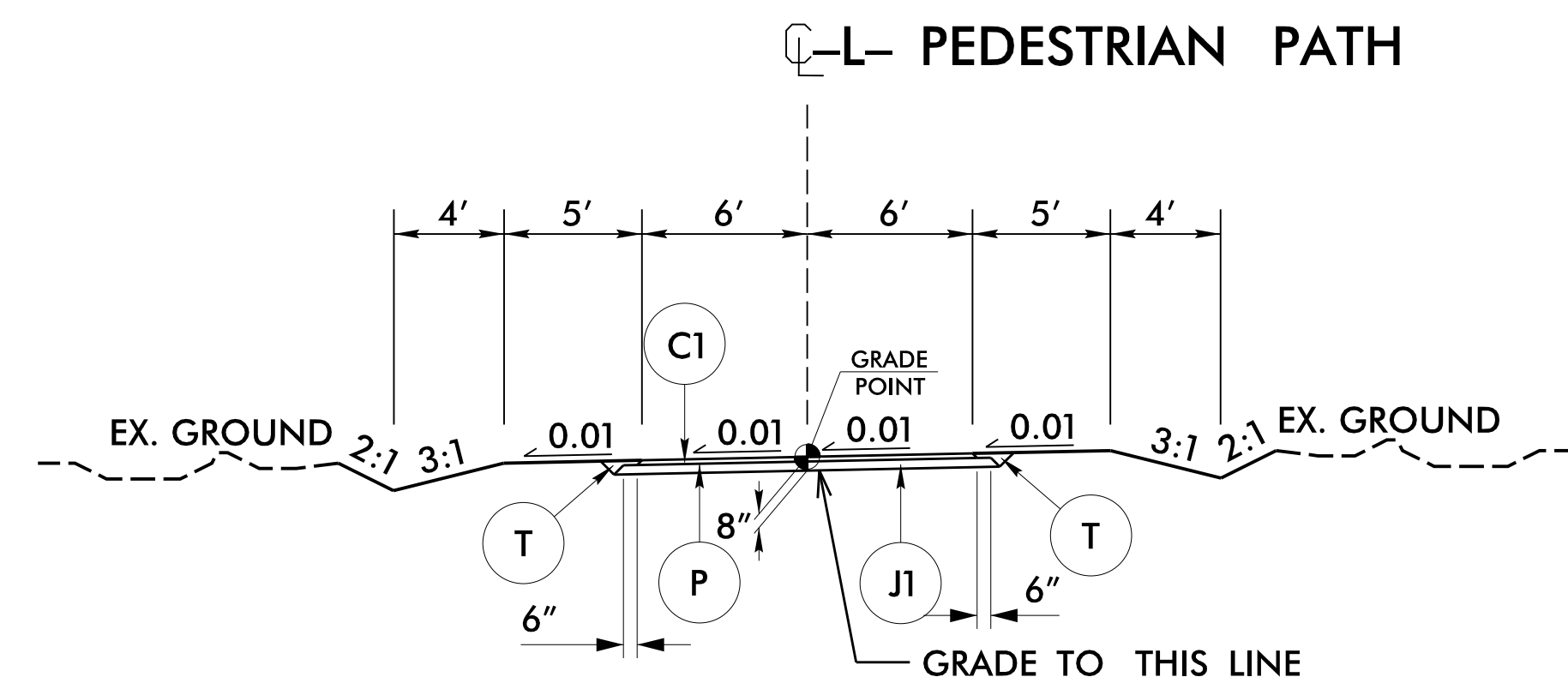

TYPICAL SECTION 3

-L- STA. 13+82.72 TO STA. 14+46.54

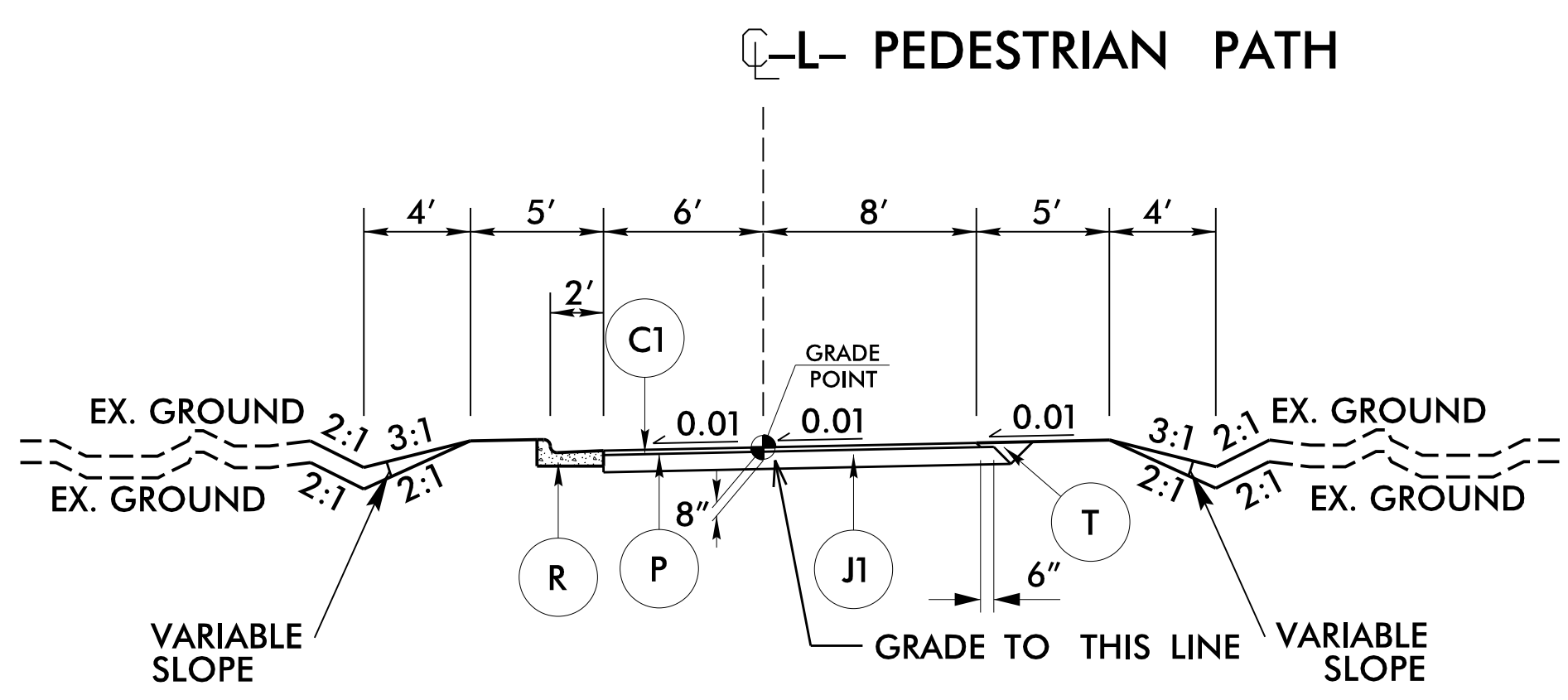

TYPICAL SECTION 2

-L- STA. 13+62.39 (END BRIDGE) TO STA. 13+82.72

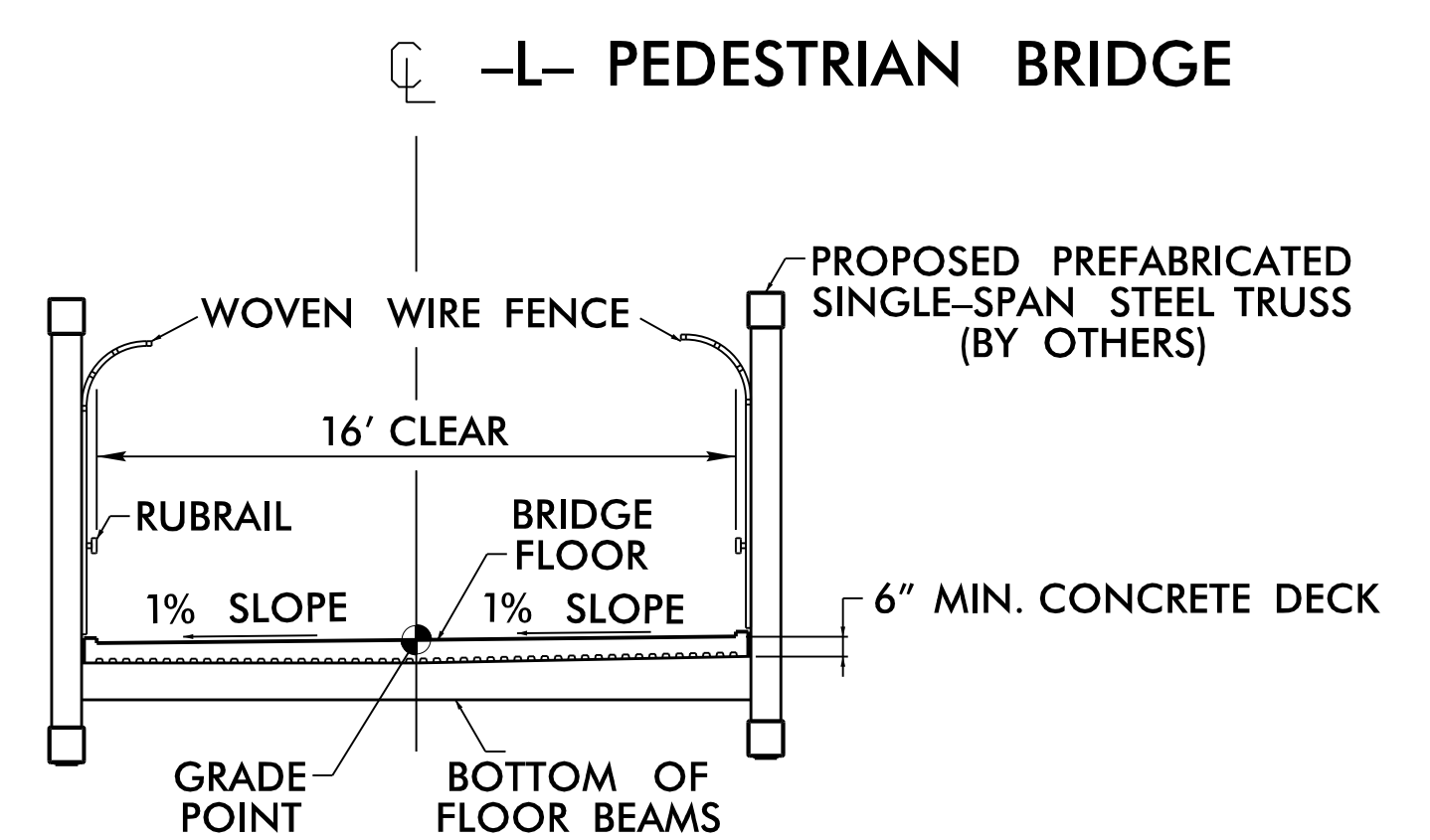

BRIDGE TYPICAL

SEE STRUCTURE PLANS

12/06/07

COMPUTED BY: JRC	DATE: 7/10/2024
CHECKED BY: ACJ	DATE: 7/23/2024

STATE OF NORTH CAROLINA
DIVISION OF HIGHWAYS



PROJECT REFERENCE NO.	SHEET NO.
51358	3B-1

SUMMARY OF EARTHWORK

STATION	STATION	UNCL. EXCAV.	EMBANK. + %	BORROW	WASTE
-L- 10 + 45.00	-L- 11 + 59.64 (BEGIN BRIDGE)	14	90		
SUBTOTALS:		14	90	76	
-L- 13 + 62.39 (END BRIDGE)	-L- 14 + 46.99	233			233
SUBTOTALS:		233			233
TOTALS		247	90	76	247
WASTE IN LIEU OF BORROW				-76	-76
PROJECT TOTALS		247	90		157
GRAND TOTALS:		247	90		157
SAY:		250			

STATE OF NORTH CAROLINA
DIVISION OF HIGHWAYS

TRANSPORTATION MANAGEMENT PLAN

WILKES COUNTY

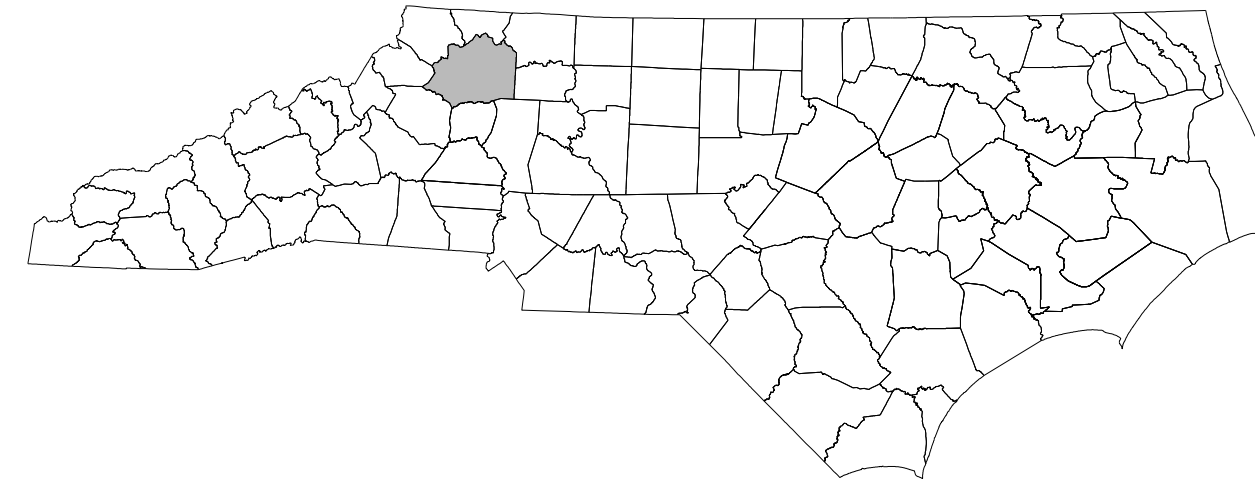

LOCATION: PEDESTRIAN BRIDGE OVER US 421 AT NORTH WILKESBORO SPEEDWAY

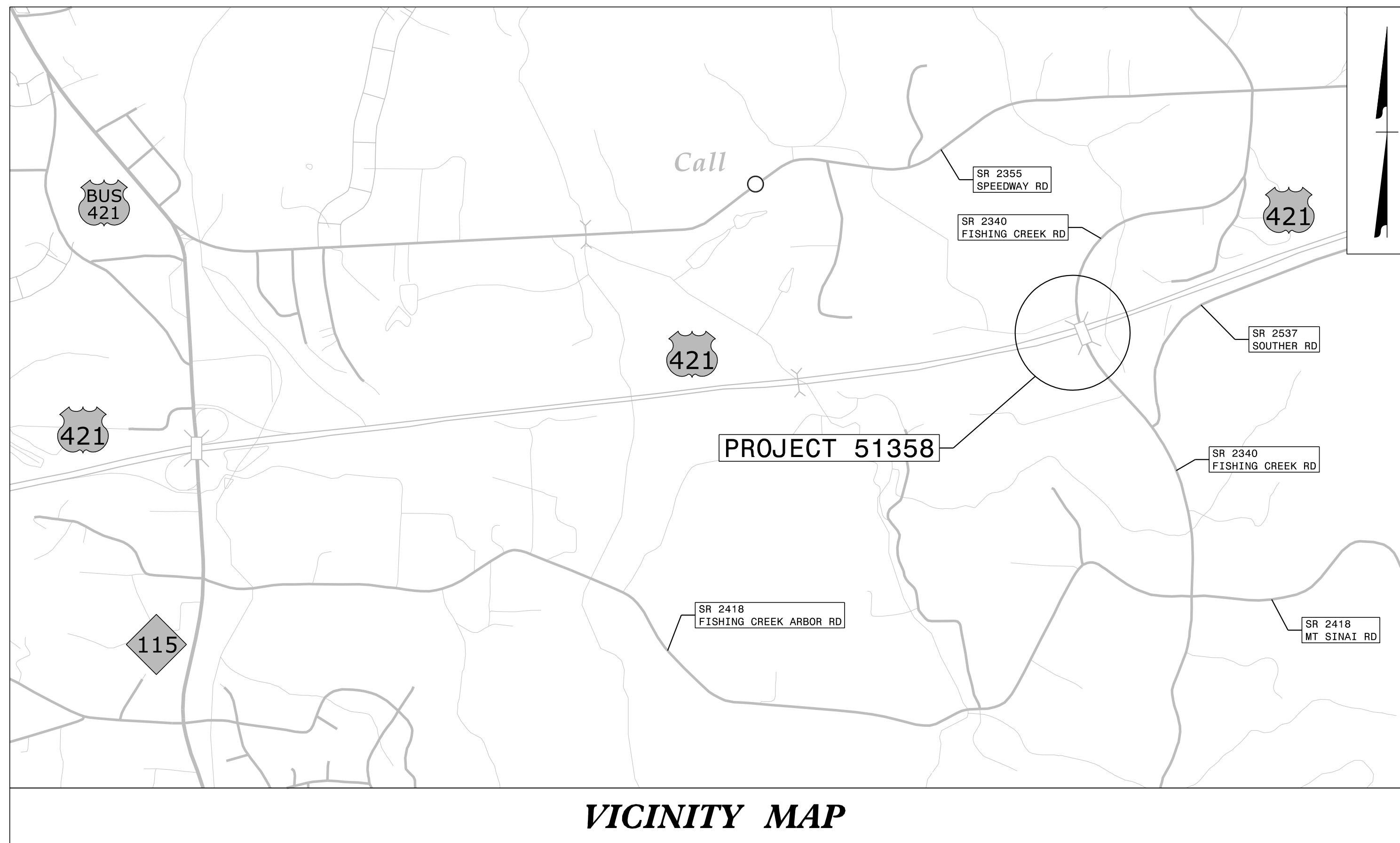

VICINITY MAP

<u>INDEX OF SHEETS</u>	
SHEET NO.	TITLE
TMP-1	TITLE SHEET, VICINITY MAP, INDEX OF SHEETS AND MANAGEMENT STRATEGIES
TMP-1A	LIST OF APPLICABLE ROADWAY STANDARD DRAWINGS AND LEGEND
TMP-1B	TRANSPORTATION OPERATIONS PLAN
TMP-3	OFFSITE DETOUR ROUTE - FISHING CREEK ROAD
TMP-4	OFFSITE DETOUR ROUTE - US 421

SHEET NO.
TMP-1

7/25/2024
pw:\gfnnet-pw-bentley.com\gfnnet-pw-0\Documents\Projects\69172\5-Working\Task 020 - Wilkesboro Speedway Ped Bridge\TrafficControl\TCP\51358_TMP_PSH01.dgn
User: bwhite

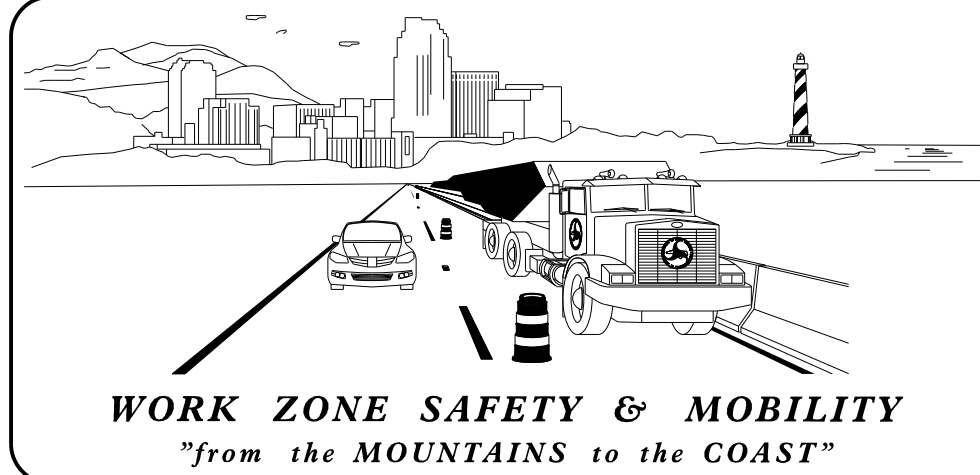

PLANS PREPARED BY:

RICKY A. TIPTON, PE
PROJECT ENGINEER

BENJAMIN A. WHITE, PE
PROJECT DESIGN ENGINEER

NCDOT CONTACTS:

RAMIE A. SHAW, PE
PROJECT DEVELOPMENT ENGINEER

CHRIS J. BROWN
DIVISION TRAFFIC ENGINEER

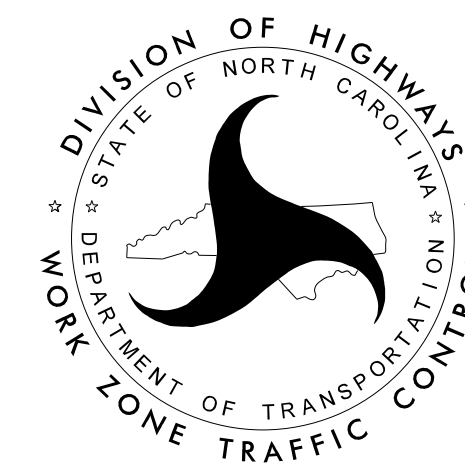

**DOCUMENT NOT CONSIDERED FINAL
UNLESS ALL SIGNATURES COMPLETED**



APPROVED: 
DocuSigned by:
Benjamin A. White
68f778221817443...

DATE: 7/26/2024

SEAL



PROJECT: 51358

ROADWAY STANDARD DRAWINGS

THE FOLLOWING ROADWAY STANDARDS AS SHOWN IN "ROADWAY STANDARD DRAWINGS" - N.C. DEPARTMENT OF TRANSPORTATION - RALEIGH, N.C., DATED JANUARY 2024 ARE APPLICABLE TO THIS PROJECT AND BY REFERENCE HEREBY ARE CONSIDERED A PART OF THESE PLANS:

STD. NO.	TITLE
1101.01	WORK ZONE WARNING SIGNS
1101.02	TEMPORARY LANE CLOSURES
1101.03	TEMPORARY ROAD CLOSURES
1101.04	TEMPORARY SHOULDER CLOSURES
1101.11	TRAFFIC CONTROL DESIGN TABLES
1110.01	STATIONARY WORK ZONE SIGNS
1110.02	PORTABLE WORK ZONE SIGNS
1115.01	FLASHING ARROW BOARDS
1130.01	DRUMS
1145.01	BARRICADES
1165.01	TRUCK MOUNTED ATTENUATOR

LEGEND

GENERAL

- DIRECTION OF TRAFFIC FLOW
- DIRECTION OF PEDESTRIAN TRAFFIC FLOW
- EXIST. PVMT.
- NORTH ARROW
- PROPOSED PVMT.
- TEMP. SHORING (LOCATION PURPOSES ONLY)

WORK AREA

REMOVAL

USER DEFINED (IF NEEDED)

USER DEFINED (IF NEEDED)

SIGNALS

- EXISTING
- PROPOSED
- TEMPORARY
- PORTABLE

PAVEMENT MARKINGS

- EXISTING LINES
- TEMPORARY LINES

TRAFFIC CONTROL DEVICES

- BARRICADE (TYPE III)
- CONE
- DRUM
- SKINNY DRUM
- TUBULAR MARKER
- TEMPORARY CRASH CUSHION
- FLASHING ARROW BOARD
- FLAGGER
- LAW ENFORCEMENT
- TRUCK MOUNTED ATTENUATOR (TMA)
- CHANGEABLE MESSAGE SIGN

TEMPORARY SIGNING

- PORTABLE SIGN
- STATIONARY SIGN
- STATIONARY OR PORTABLE SIGN

PAVEMENT MARKERS

- CRYSTAL/CRYSTAL
- CRYSTAL/RED
- YELLOW/YELLOW

PAVEMENT MARKING SYMBOLS

- PAVEMENT MARKING SYMBOLS

7/25/2024
 pw:\gfn\pw.bentley.com\gfn\Projects\69172\5-Working\Task 020 - Wilkesboro Speedway Ped Bridge\TrafficControl\TCP\51358_TMP_PSHA.dgn
 User: bwhite



APPROVED:
 DATE: 7/26/2024

SEAL

DOCUMENT NOT CONSIDERED FINAL
UNLESS ALL SIGNATURES COMPLETED

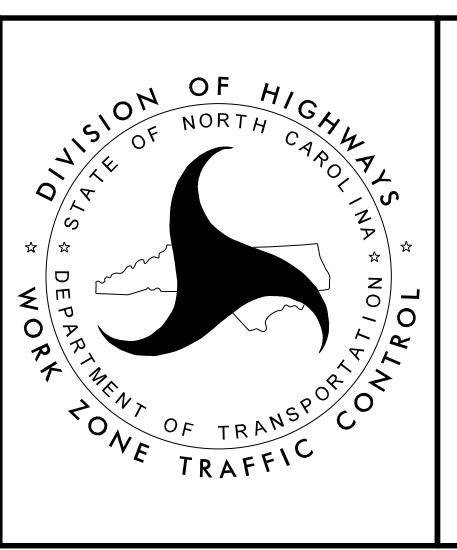

ROADWAY STANDARD
DRAWINGS & LEGEND

GENERAL NOTES

CHANGES MAY BE REQUIRED WHEN PHYSICAL DIMENSIONS IN THE DETAIL DRAWINGS, STANDARD DETAILS, AND ROADWAY DETAILS ARE NOT ATTAINABLE TO MEET FIELD CONDITIONS OR RESULT IN DUPLICATE OR UNDESIRE OVERLAPPING OF DEVICES. MODIFICATION MAY INCLUDE: MOVING, SUPPLEMENTING, COVERING, OR REMOVAL OF DEVICES AS DIRECTED BY THE ENGINEER.

THE FOLLOWING GENERAL NOTES APPLY AT ALL TIMES FOR THE DURATION OF THE CONSTRUCTION PROJECT EXCEPT WHEN OTHERWISE NOTED IN THE PLAN OR DIRECTED BY THE ENGINEER.

TIME RESTRICTIONS:

A) DO NOT CLOSE OR NARROW TRAVEL LANES AS FOLLOWS:

ROAD NAME	DAY AND TIME RESTRICTIONS
US 421	MONDAY THRU SUNDAY 6:00 A.M. TO 7:00 P.M.

B) DO NOT CLOSE OR NARROW TRAVEL LANES DURING HOLIDAYS AND SPECIAL EVENTS AS FOLLOWS:

ROAD NAME
US 421
SR 2340 FISHING CREEK RD
SR 2418 FISHING CREEK ARBOR RD
SR 2355 SPEEDWAY RD
NC 115/BUSINESS 421

HOLIDAY

- FOR ANY UNEXPECTED OCCURRENCE THAT CREATES UNUSUALLY HIGH TRAFFIC VOLUMES, AS DIRECTED BY THE ENGINEER.
- FOR NEW YEAR'S, BETWEEN THE HOURS OF 6:00 A.M. DECEMBER 31st TO 7:00 P.M. JANUARY 2ND. IF NEW YEAR'S DAY IS ON A FRIDAY, SATURDAY, SUNDAY, OR MONDAY THEN UNTIL 7:00 P.M. THE FOLLOWING TUESDAY.
- FOR EASTER, BETWEEN THE HOURS OF 6:00 A.M. THURSDAY AND 7:00 P.M. MONDAY.
- FOR MEMORIAL DAY, BETWEEN THE HOURS OF 6:00 A.M. FRIDAY TO 7:00 P.M. TUESDAY.
- FOR INDEPENDENCE DAY, BETWEEN THE HOURS OF 6:00 A.M. THE DAY BEFORE INDEPENDENCE DAY AND 7:00 P.M. THE DAY AFTER INDEPENDENCE DAY.

IF INDEPENDENCE DAY IS ON A FRIDAY, SATURDAY, SUNDAY OR MONDAY THEN BETWEEN THE HOURS OF 6:00 A.M. THE THURSDAY BEFORE INDEPENDENCE DAY AND 7:00 P.M. THE TUESDAY AFTER INDEPENDENCE DAY.
- FOR LABOR DAY, BETWEEN THE HOURS OF 6:00 A.M. FRIDAY AND 7:00 P.M. TUESDAY.
- FOR THANKSGIVING DAY, BETWEEN THE HOURS OF 6:00 A.M. TUESDAY TO 7:00 P.M. MONDAY.
- FOR CHRISTMAS, BETWEEN THE HOURS OF 6:00 A.M. THE FRIDAY BEFORE THE WEEK OF CHRISTMAS DAY AND 7:00 P.M. THE FOLLOWING TUESDAY AFTER THE WEEK OF CHRISTMAS.

LANE AND SHOULDER CLOSURE REQUIREMENTS

D) WHEN PERSONNEL AND/OR EQUIPMENT ARE WORKING WITHIN 15 FT OF AN OPEN TRAVEL LANE, CLOSE THE NEAREST OPEN SHOULDER USING ROADWAY STANDARD DRAWING NO. 1101.04 UNLESS THE WORK AREA IS PROTECTED BY BARRIER OR GUARDRAIL OR A LANE CLOSURE IS INSTALLED.

E) WHEN PERSONNEL AND/OR EQUIPMENT ARE WORKING ON THE SHOULDER ADJACENT TO AN UNDIVIDED FACILITY AND WITHIN 5 FT OF AN OPEN TRAVEL LANE, CLOSE THE NEAREST OPEN TRAVEL LANE USING ROADWAY STANDARD DRAWING NO. 1101.02 UNLESS THE WORK AREA IS PROTECTED BY BARRIER OR GUARDRAIL.

WHEN PERSONNEL AND/OR EQUIPMENT ARE WORKING ON THE SHOULDER ADJACENT TO A DIVIDED FACILITY AND WITHIN 10 FT OF AN OPEN TRAVEL LANE, CLOSE THE NEAREST OPEN TRAVEL LANE USING ROADWAY STANDARD DRAWING NO. 1101.02 UNLESS THE WORK AREA IS PROTECTED BY BARRIER OR GUARDRAIL.

TRAFFIC PATTERN ALTERATIONS

F) NOTIFY THE ENGINEER THIRTY (30) CALENDAR DAYS PRIOR TO ANY TRAFFIC PATTERN ALTERATION.

SIGNING

G) INSTALL ADVANCE WORK ZONE WARNING SIGNS WHEN WORK IS WITHIN 40 FT FROM THE EDGE OF TRAVEL LANE AND NO MORE THAN THREE (3) DAYS PRIOR TO THE BEGINNING OF CONSTRUCTION.

H) PROVIDE SIGNING AND DEVICES REQUIRED TO CLOSE THE ROAD ACCORDING TO THE ROADWAY STANDARD DRAWINGS AND TRAFFIC CONTROL PLANS.

PROVIDE SIGNING REQUIRED FOR THE OFF-SITE DETOUR ROUTE AS SHOWN IN THE TRAFFIC CONTROL PLANS.

I) COVER OR REMOVE ALL SIGNS AND DEVICES REQUIRED TO CLOSE THE ROAD WHEN ROAD CLOSURE IS NOT IN OPERATION.

COVER OR REMOVE ALL SIGNS REQUIRED FOR THE OFF-SITE DETOUR WHEN THE DETOUR IS NOT IN OPERATION.

J) ENSURE ALL NECESSARY SIGNING IS IN PLACE PRIOR TO ALTERING ANY TRAFFIC PATTERN.

TRAFFIC CONTROL DEVICES

K) PLACE TYPE III BARRICADES, WITH "ROAD CLOSED" SIGN R11-2 ATTACHED, OF SUFFICIENT LENGTH TO CLOSE ENTIRE ROADWAY.

MISCELLANEOUS

L) LAW ENFORCEMENT MAY BE USED TO MAINTAIN TRAFFIC THROUGH THE WORK AREA AND/OR INTERSECTIONS AS DIRECTED BY THE ENGINEER.

PHASING

COMPLETE THE REQUIREMENTS OF PHASE I, STEP 5 WITHIN A SINGLE CLOSURE PERIOD BETWEEN THE HOURS OF 9:00 P.M. AND 5:00 A.M. SEE INTERMEDIATE CONTRACT TIME AND LIQUIDATED DAMAGES.

COMPLETE THE REQUIREMENTS OF PHASE I, STEP 4 WITHIN A CONSECUTIVE SEVENTY-TWO (72) HOUR PERIOD. SEE INTERMEDIATE CONTRACT TIME AND LIQUIDATED DAMAGES.

PHASE I

STEP 1: USING ROADWAY STANDARD DRAWING 1101.01 SHEET 1 OF 3, INSTALL WORK ZONE ADVANCE WARNING SIGNS ON NORTHBOUND AND SOUTHBOUND US 421.

STEP 2: USING ROADWAY STANDARD DRAWING 1101.04 SHEET 1 OF 2, INSTALL TEMPORARY SHOULDER CLOSURES ON OUTSIDE SHOULDERS OF NORTHBOUND AND SOUTHBOUND US 421 TO COMPLETE WORK ON PROPOSED END BENTS AND SLOPE PROTECTION.

STEP 3: AWAY FROM TRAFFIC, COMPLETE PROPOSED BRIDGE ABUTMENT AND PEDESTRIAN PATHWAY APPROACH WORK FROM -L- STA. 10+45.00 TO STA. 11+59.64 AND -L- STA. 13+62.39 TO 14+46.99.

STEP 4: USING SHEET TMP-3 AND ROADWAY STANDARD DRAWING 1101.03 SHEET 1 OF 9, INSTALL DETOUR ROUTE SIGNING TO CLOSE SR 2340 (FISHING CREEK RD). COMPLETE STEP 4 IN A CONSECUTIVE SEVENTY-TWO (72) HOUR PERIOD IN CONJUNCTION WITH STEP 5.

STEP 5: USING SHEET TMP-4 AND ROADWAY STANDARD DRAWING 1101.03 SHEET 7 OF 9, INSTALL DETOUR ROUTE SIGNING TO CLOSE US 421. ALL OPERATIONS REQUIRED TO SET BRIDGE IN FINAL POSITION ARE TO BE COMPLETED DURING ONE TIME PERIOD BETWEEN THE HOURS OF 9:00 P.M. AND 5:00 A.M.

STEP 6: ONCE BRIDGE IS PLACED IN FINAL POSITION, REMOVE TEMPORARY TRAFFIC CONTROL DEVICES AND OFFSITE DETOUR SIGNING AND RETURN ROADWAY BACK TO REGULAR TRAFFIC PATTERN.

7/26/2024 pw:\gfn\pw-bentley.com\gfn\pw-0\Documents\Projects\69172\5-Working\Task 020 - Wilkesboro Speedway Ped Bridge\TrafficControl\TCP\51358_TMP_PSHIB.dgn User:bwht

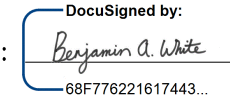
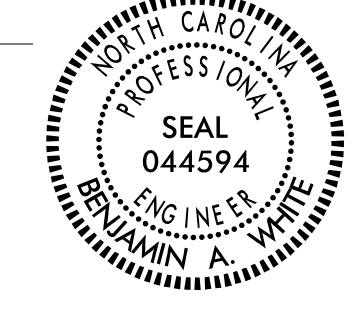
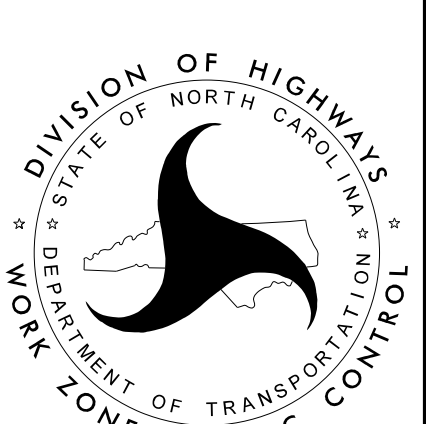
APPROVED:  DATE: 7/26/2024 SEAL 		TRANSPORTATION OPERATIONS PLAN
DOCUMENT NOT CONSIDERED FINAL UNLESS ALL SIGNATURES COMPLETED		

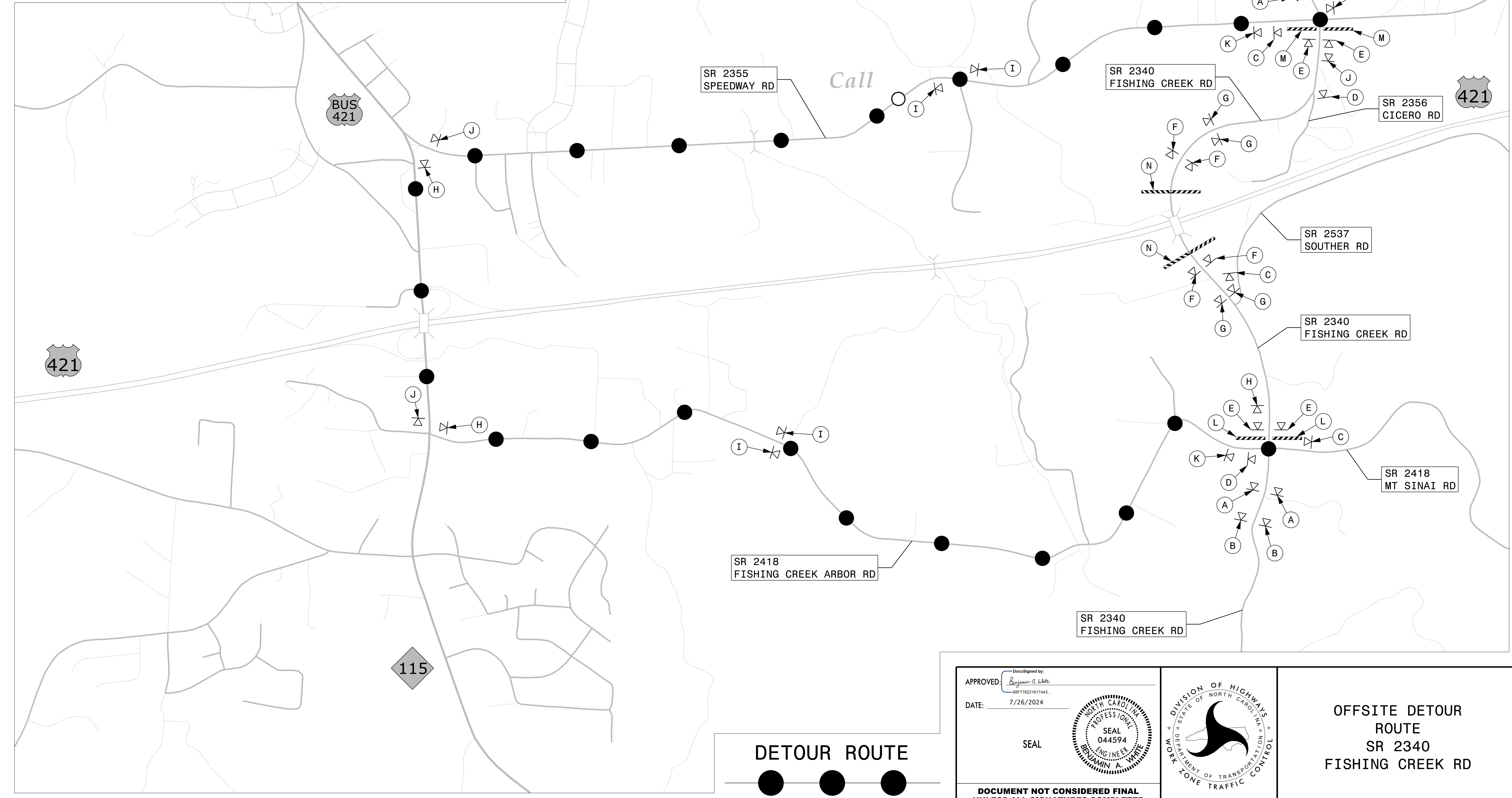
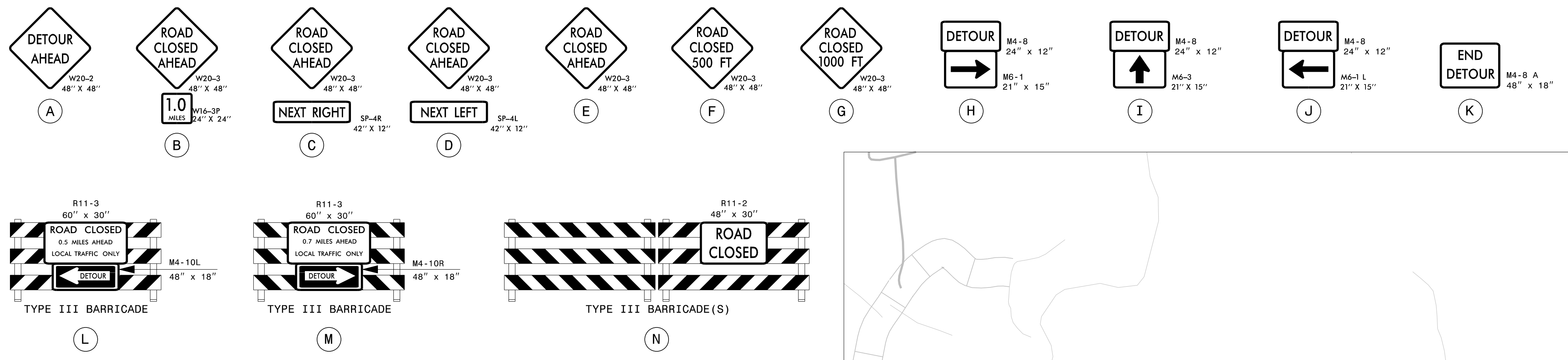

7/25/2024
pw:\gfnnet-pw-bentley.com\gfnnet-pw-0\Documents\Projects\69172\5-Working\Task 020 - Wilkesboro Speedway Ped Bridge\Traffic\TrafficControl\TCP\51358_TMP_PSH03.dgn
User:bwwhite

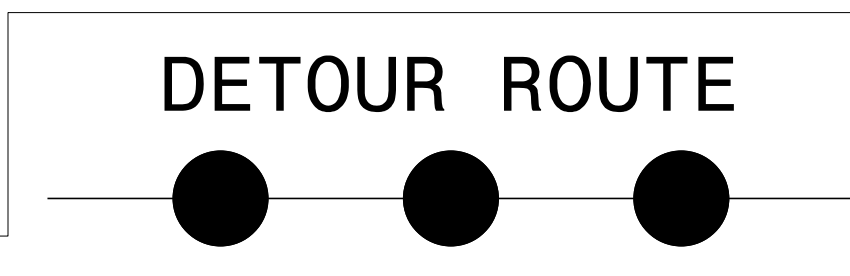

APPROVED: *Benjamin A. White*
DATE: 7/26/2024

SEAL

DOCUMENT NOT CONSIDERED FINAL
UNLESS ALL SIGNATURES COMPLETED

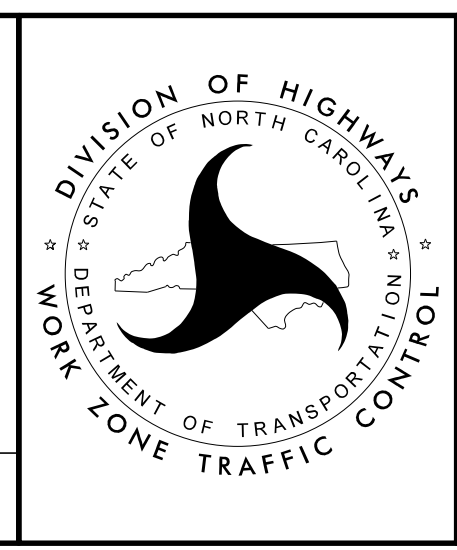

OFFSITE DETOUR
ROUTE
SR 2340
FISHING CREEK RD

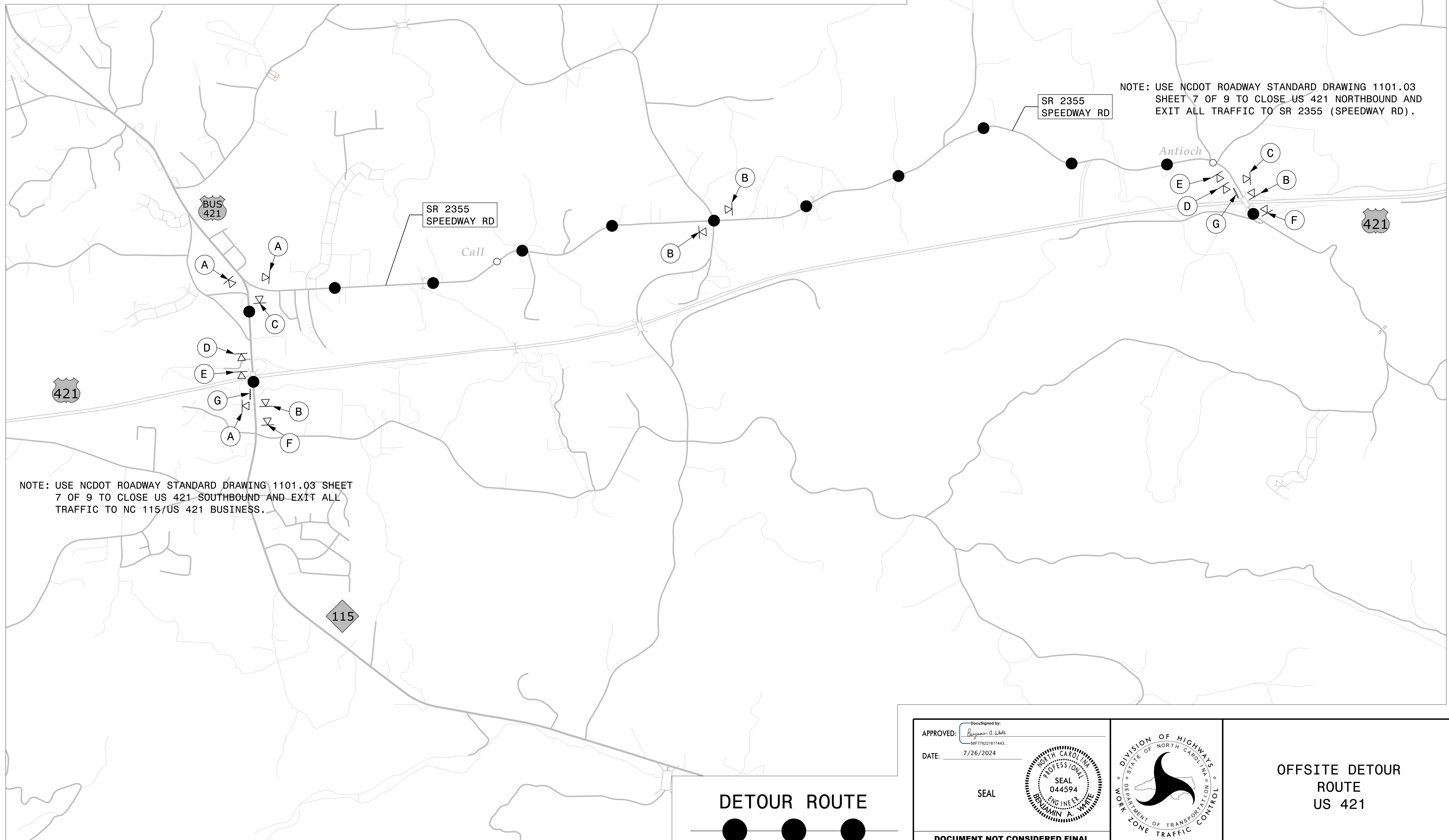
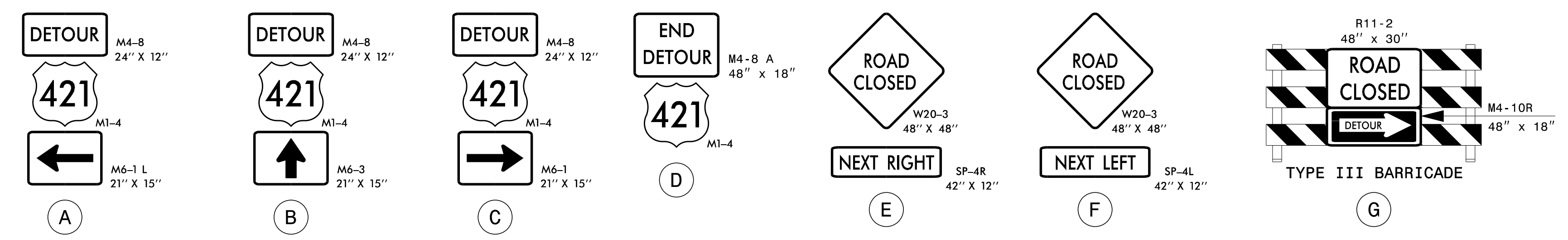

NOTE: USE NCDOT ROADWAY STANDARD DRAWING 1101.03 SHEET 7 OF 9 TO CLOSE US 421 SOUTHBOUND AND EXIT ALL TRAFFIC TO NC 115/US 421 BUSINESS.

NOTE: USE NCDOT ROADWAY STANDARD DRAWING 1101.03 SHEET 7 OF 9 TO CLOSE US 421 NORTHBOUND AND EXIT ALL TRAFFIC TO SR 2355 (SPEEDWAY RD).

7/25/2024 pw:\gfnnet-pw-bentley.com\gfnnet-pw-0\Documents\Projects\69172\5-Working\Task 020 - Wilkesboro Speedway Ped Bridge\TrafficControl\51358_TMP_PSH04.dgn User:bwht

DETOUR ROUTE

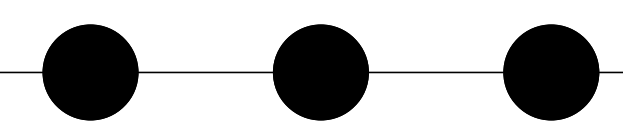

APPROVED: *Benjamin A. White*
 DATE: 7/26/2024

SEAL

**DOCUMENT NOT CONSIDERED FINAL
UNLESS ALL SIGNATURES COMPLETED**

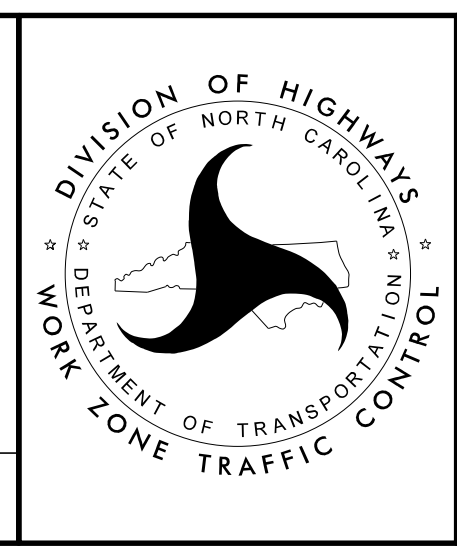

OFFSITE DETOUR
ROUTE
US 421

TIP PROJECT: 51358

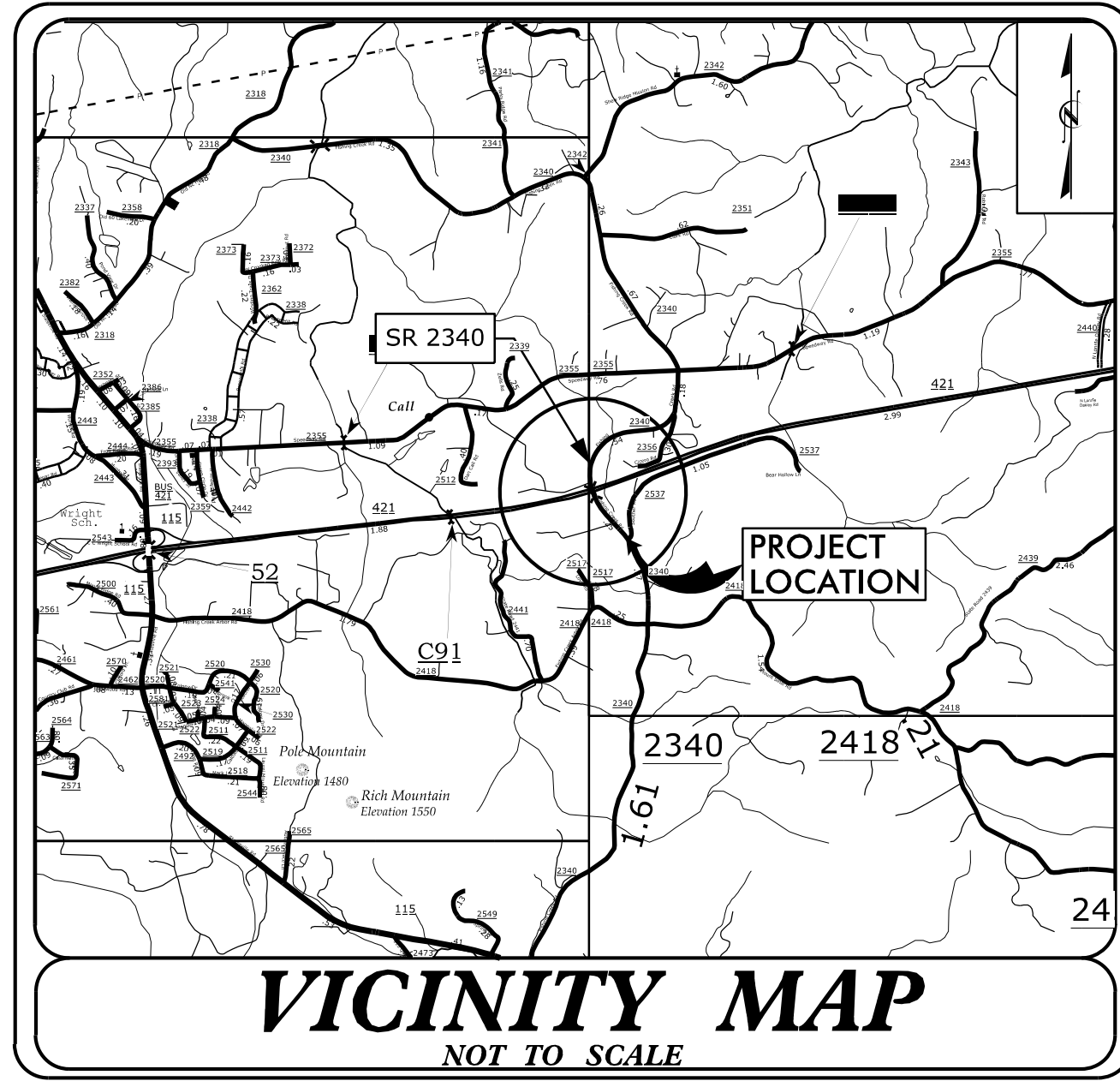

STATE OF NORTH CAROLINA
DIVISION OF HIGHWAYS

PLAN FOR PROPOSED
HIGHWAY EROSION CONTROL

WILKES COUNTY

LOCATION: PEDESTRIAN BRIDGE OVER US 421 AT NORTH WILKESBORO SPEEDWAY

TYPE OF WORK: GRADING, DRAINAGE, PAVING & STRUCTURE

STATE	STATE PROJECT REFERENCE NO.	SHEET NO.	TOTAL SHEETS
N.C.	51358	EC-1	
STATE PROJ. NO.	F.A. PROJ. NO.	DESCRIPTION	

DIVISION 11

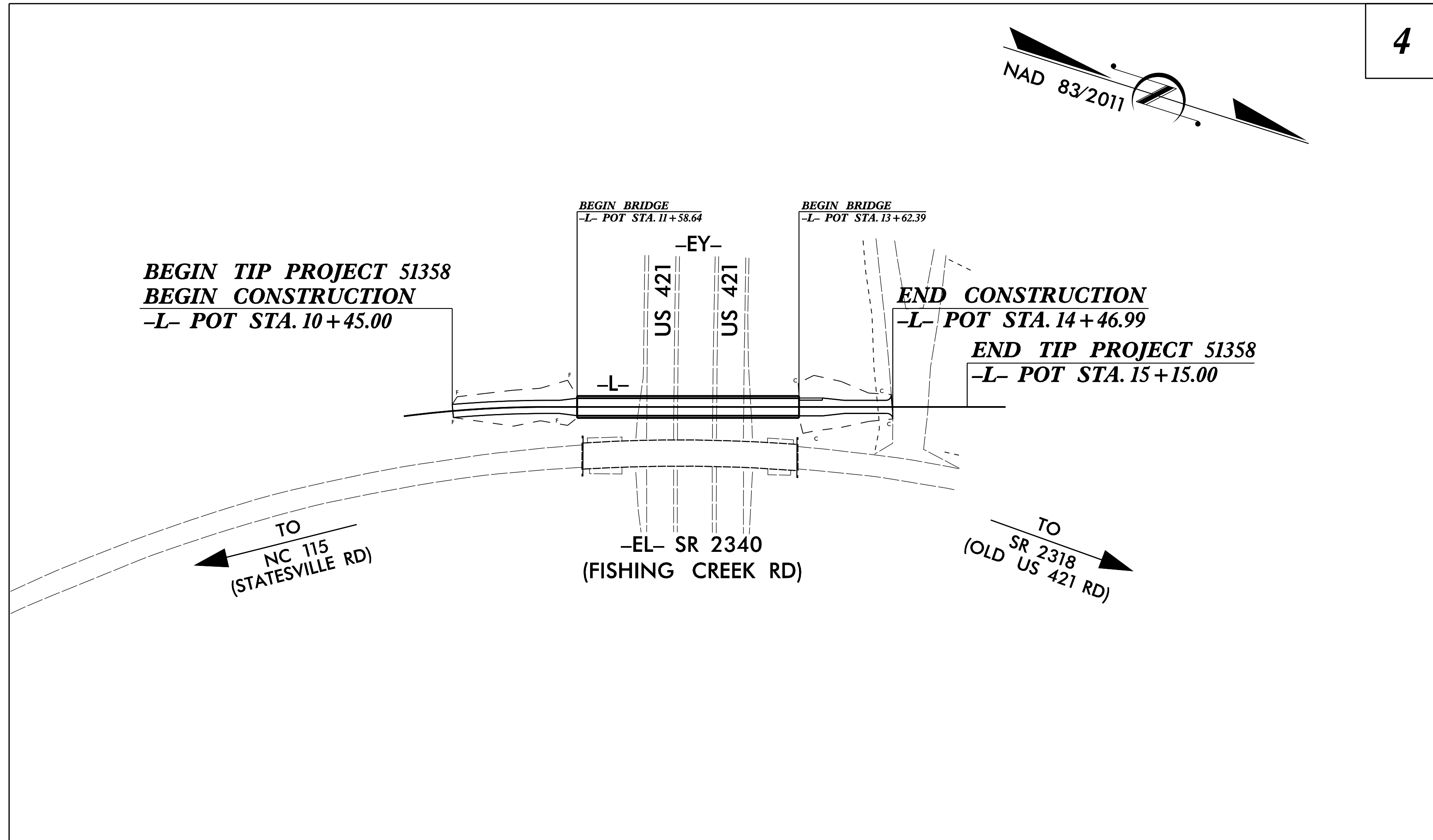
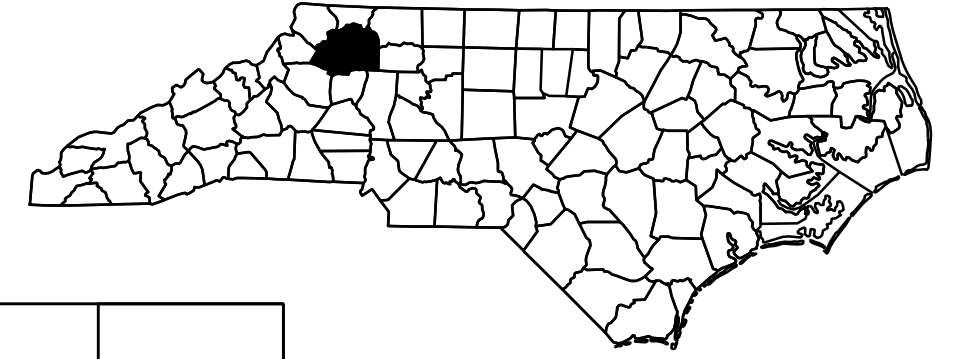

4

THIS PROJECT CONTAINS EROSION CONTROL PLANS FOR CLEARING AND GRUBBING PHASE OF CONSTRUCTION.

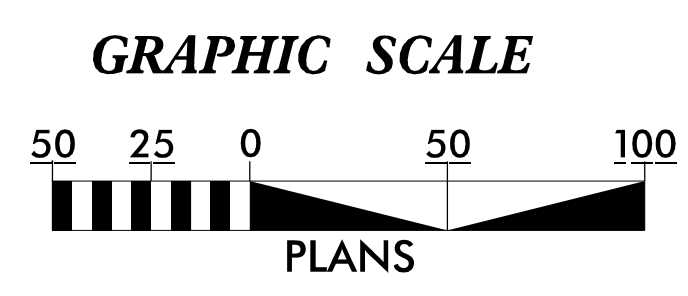

THESE EROSION AND SEDIMENT CONTROL PLANS COMPLY WITH THE REGULATIONS SET FORTH BY THE NCG-010000 GENERAL CONSTRUCTION PERMIT ISSUED BY THE NORTH CAROLINA DEPARTMENT OF ENVIRONMENT AND NATURAL RESOURCES DIVISION OF WATER QUALITY.

Prepared in the Office of:
 **GANNETT FLEMING**
 One Glenwood Avenue
 Suite 900
 Raleigh, NC 27603
 919-420-7660
 NC Lic. No. F-0270

2024 STANDARD SPECIFICATIONS

Designed by:
Nicolette Jackson 4719
 NAME LEVEL III CERTIFICATION NO.

Roadway Standard Drawings











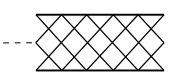
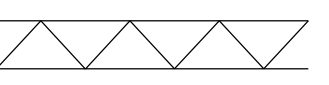
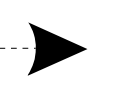
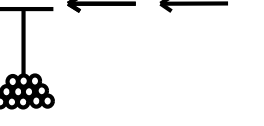
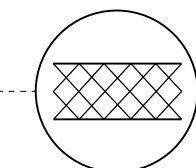
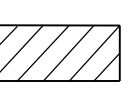
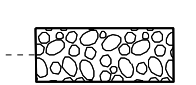

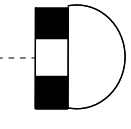
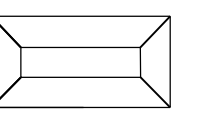

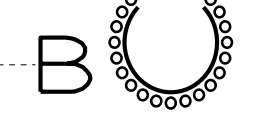
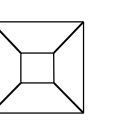

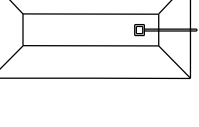
The "Roadway Standard Drawings"- Roadway Design Unit - N. C. Department of Transportation - Raleigh, N. C., dated January 2024 and the latest revision thereto are applicable to this project and by reference hereby are considered a part of these plans.

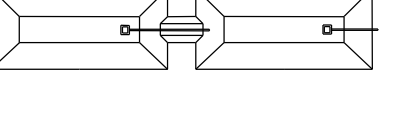
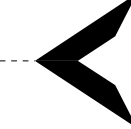
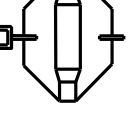
22 JUL 2024 10:51 AM P:\Projects\2024\51358\Wilkesboro Speedway Ped Bridge\Erosion Control\CAD\51358_EC.tch.dgn

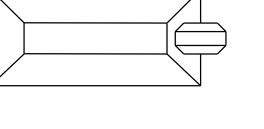
DIVISION OF HIGHWAYS STATE OF NORTH CAROLINA

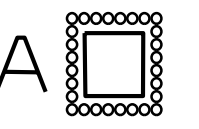
PROJECT REFERENCE NO. 51358	SHEET NO. EC-02
ROADWAY DESIGN ENGINEER	HYDRAULICS ENGINEER

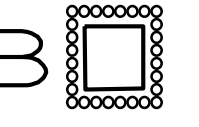
EROSION & SEDIMENT CONTROL LEGEND

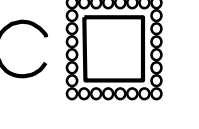
<u>Std. #</u>	<u>Description</u>	<u>Symbol</u>	<u>Std. #</u>	<u>Description</u>	<u>Symbol</u>
1605.01	Temporary Silt Fence		1633.01	Temporary Rock Silt Check Type A	
1606.01	Special Sediment Control Fence		1633.02	Temporary Rock Silt Check Type B	
1622.01	Temporary Berms and Slope Drains		1633.03	Temporary Rock Silt Check Type A with Excelsior Matting and Flocculant	
1630.02	Silt Basin Type B		1634.01	Temporary Rock Sediment Dam Type A	
1630.03	Temporary Silt Ditch		1634.02	Temporary Rock Sediment Dam Type B	
1630.04	Stilling Basin		1635.01	Rock Pipe Inlet Sediment Trap Type A	
1630.05	Temporary Diversion		1635.02	Rock Pipe Inlet Sediment Trap Type B	
1630.06	Special Stilling Basin		1636.01	Excelsior Wattle Check	
1630.07	Skimmer Basin		1636.01	Excelsior Wattle Check with Flocculant	
1630.08	Tiered Skimmer Basin		1636.01	Coir Fiber Wattle Check	
1630.09	Earthen Dam with Skimmer		1636.01	Coir Fiber Wattle Check with Flocculant	
	Infiltration Basin		1636.02	Silt Fence Excelsior Wattle Break	
	Rock Inlet Sediment Trap:			Silt Fence Coir Fiber Wattle Break	
1632.01	Type A		1636.03	Excelsior Wattle Barrier	
1632.02	Type B		1636.03	Coir Fiber Wattle Barrier	
1632.03	Type C				

DIVISION OF HIGHWAYS
STATE OF NORTH CAROLINA

PROJECT REFERENCE NO. <i>51358</i>	SHEET NO. <i>EC-3A</i>
ROADWAY DESIGN ENGINEER	HYDRAULICS ENGINEER

SOIL STABILIZATION TIMEFRAMES

<i>SITE DESCRIPTION</i>	<i>STABILIZATION TIME</i>	<i>TIMEFRAME EXCEPTIONS</i>
PERIMETER DIKES, SWALES, DITCHES AND SLOPES	7 DAYS	NONE
HIGH QUALITY WATER (HQW) ZONES	7 DAYS	NONE
SLOPES STEEPER THAN 3:1	7 DAYS	IF SLOPES ARE 10' OR LESS IN LENGTH AND ARE NOT STEEPER THAN 2:1, 14 DAYS ARE ALLOWED.
SLOPES 3:1 TO 4:1	14 DAYS	7 DAYS FOR SLOPES GREATER THAN 50' IN LENGTH WITH SLOPES STEEPER THAN 4:1. 7 DAYS FOR PERIMETER DIKES, SWALES, DITCHES PERIMETER SLOPES, AND HQW ZONES
ALL OTHER AREAS WITH SLOPES FLATTER THAN 4:1	14 DAYS	7 DAYS FOR PERIMETER DIKES, SWALES, DITCHES PERIMETER SLOPES, AND HQW ZONES

PROJECT REFERENCE NO.	SHEET NO.
051358	EC-3B
RW SHEET NO.	
ROADWAY DESIGN ENGINEER	HYDRAULICS ENGINEER

ONSITE CONCRETE WASHOUT STRUCTURE WITH LINER

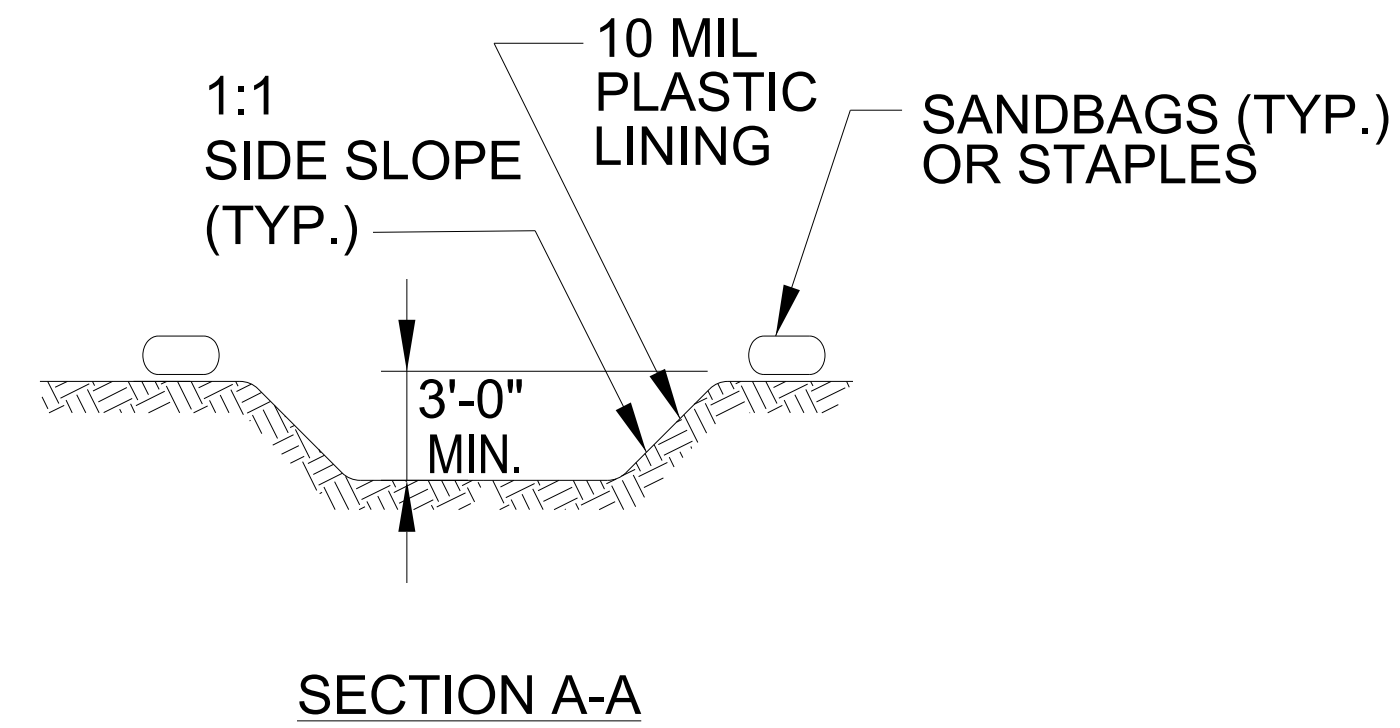
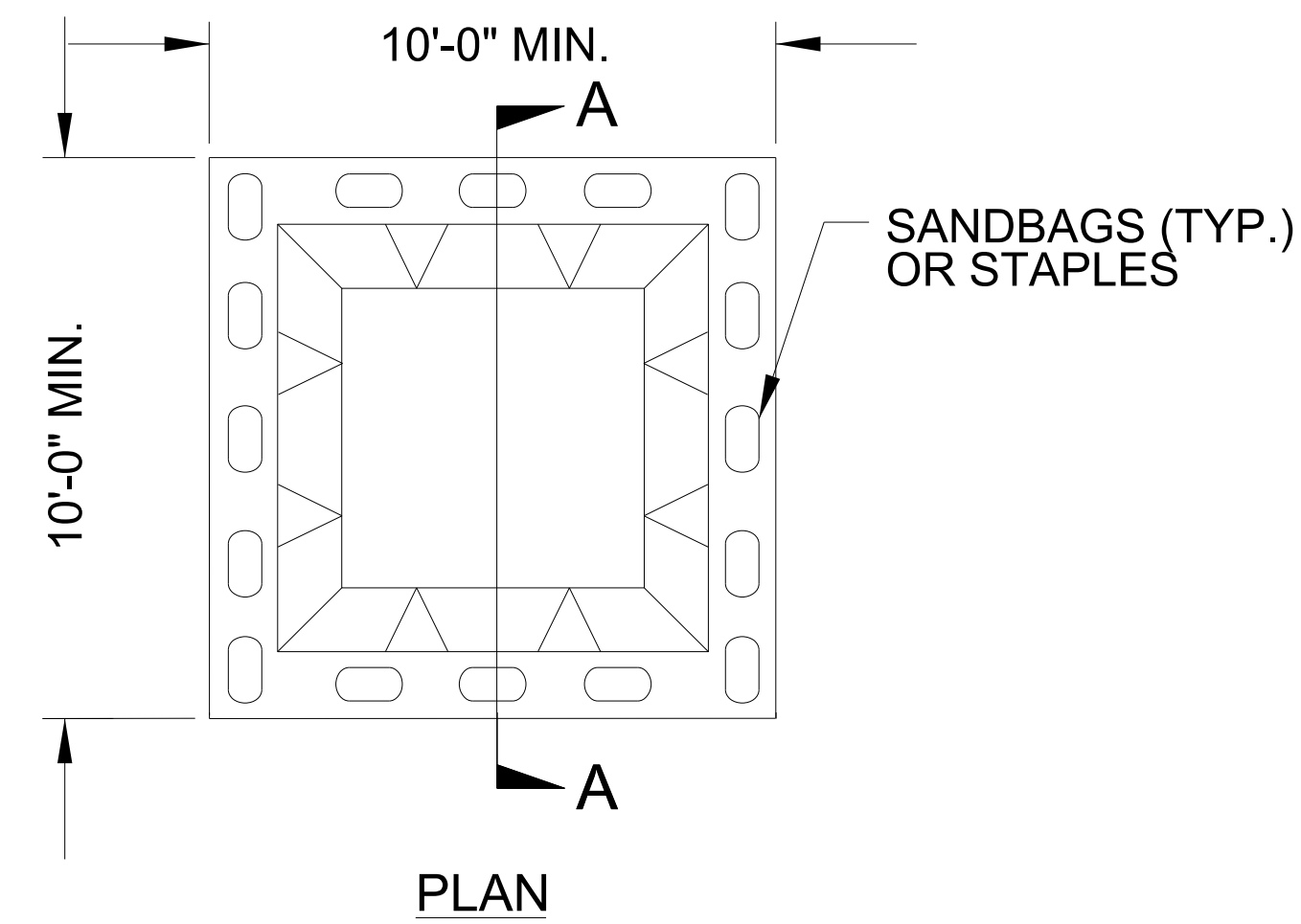

BELOW GRADE WASHOUT STRUCTURE
NOT TO SCALE

- NOTES:
1. ACTUAL LOCATION DETERMINED IN FIELD
 2. THE CONCRETE WASHOUT STRUCTURES SHALL BE MAINTAINED WHEN THE LIQUID AND/OR SOLID REACHES 75% OF THE STRUCTURES CAPACITY TO PROVIDE ADEQUATE HOLDING CAPACITY WITH A MINIMUM 12 INCHES OF FREEBOARD.
 3. CONCRETE WASHOUT STRUCTURE NEEDS TO BE CLEARLY MARKED WITH SIGNAGE NOTING DEVICE.

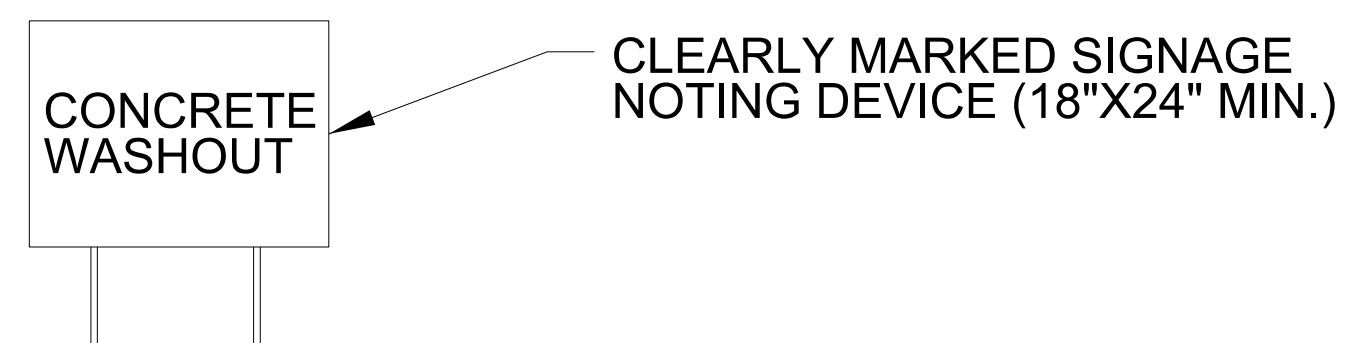
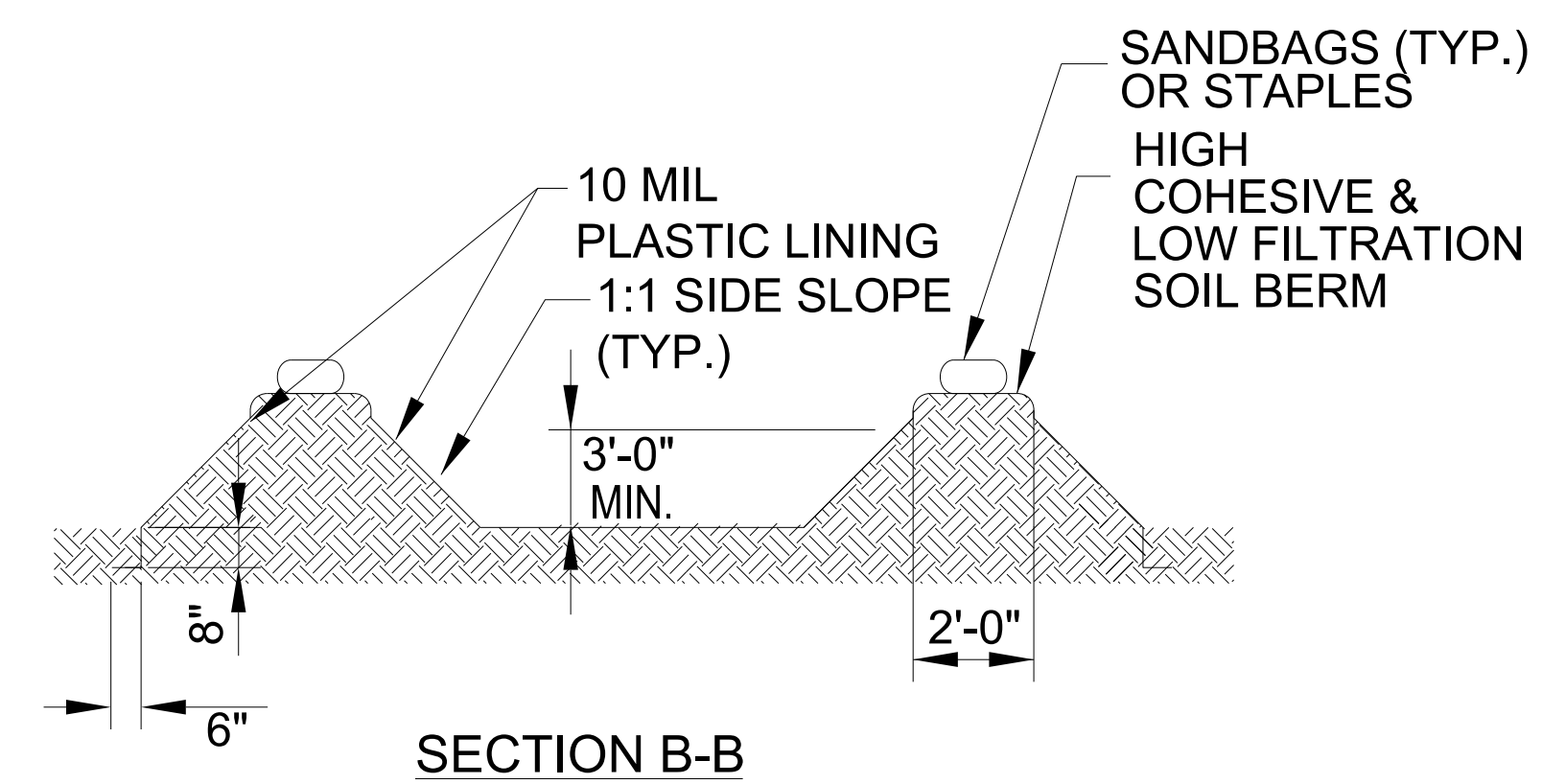
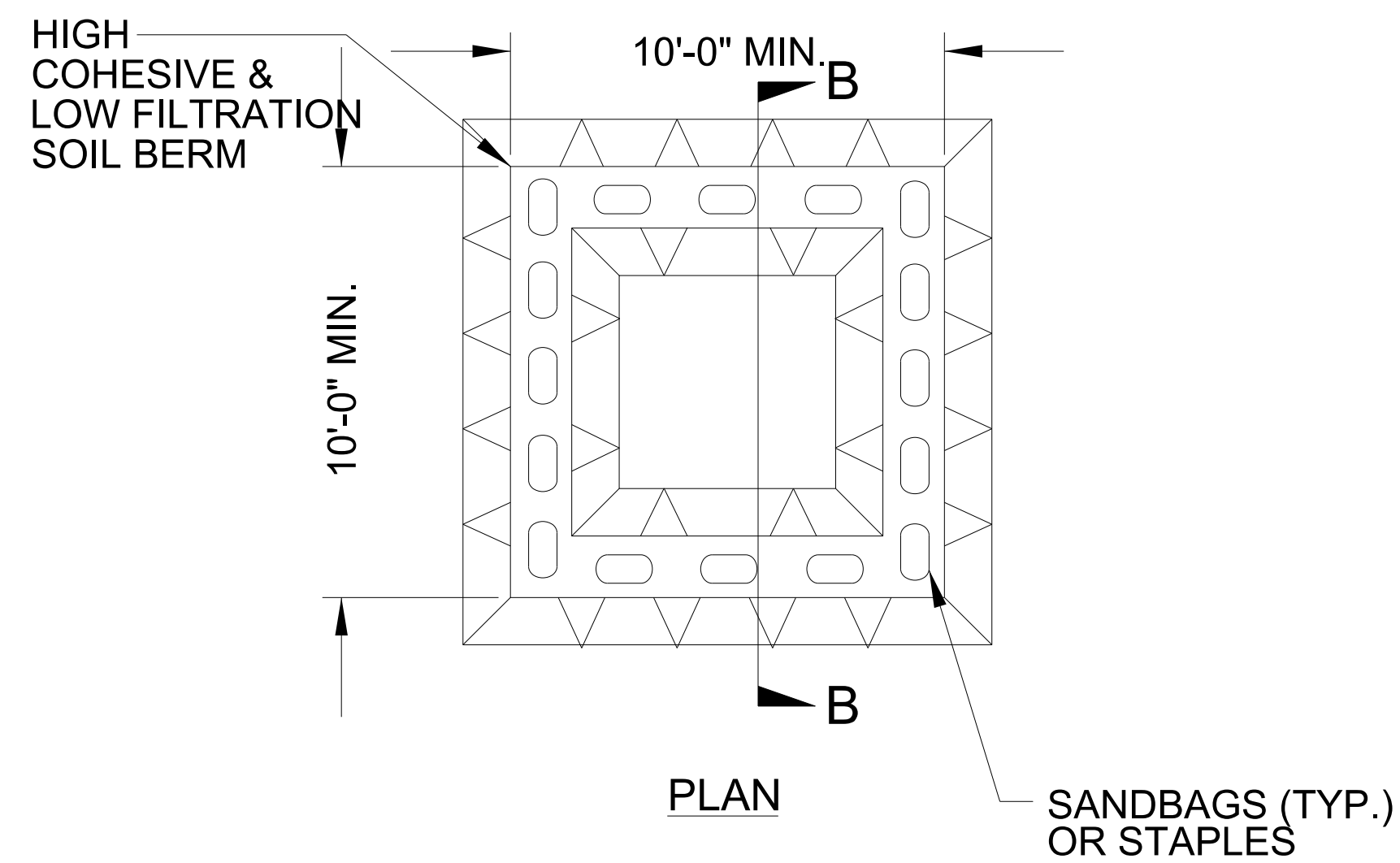

ABOVE GRADE WASHOUT STRUCTURE
NOT TO SCALE

- NOTES:
1. ACTUAL LOCATION DETERMINED IN FIELD
 2. THE CONCRETE WASHOUT STRUCTURES SHALL BE MAINTAINED WHEN THE LIQUID AND/OR SOLID REACHES 75% OF THE STRUCTURES CAPACITY TO PROVIDE ADEQUATE HOLDING CAPACITY WITH A MINIMUM 12 INCHES OF FREEBOARD.
 3. CONCRETE WASHOUT STRUCTURE NEEDS TO BE CLEARLY MARKED WITH SIGNAGE NOTING DEVICE.

8/17/99

NOTE:
PERIMETER EROSION CONTROL MEASURES SHALL BE
INSTALLED DURING CLEARING AND GRUBBING PHASE.

CLEARING AND GRUBBING
EROSION CONTROL FOR
CONSTRUCTION SHEET 4

$\Delta = 7' 26' 21.5" (RT)$
 $D = 5' 40' 22.3"$
 $L = 131.14'$
 $T = 65.66'$
 $R = 1,010.00'$
 $DS = 18 MPH$



PROJECT REFERENCE NO.	SHEET NO.
51358	EC-4/CONST-4
RW SHEET NO.	
ROADWAY DESIGN ENGINEER	HYDRAULICS ENGINEER
INCOMPLETE PLANS DO NOT USE FOR R/W ACQUISITION	

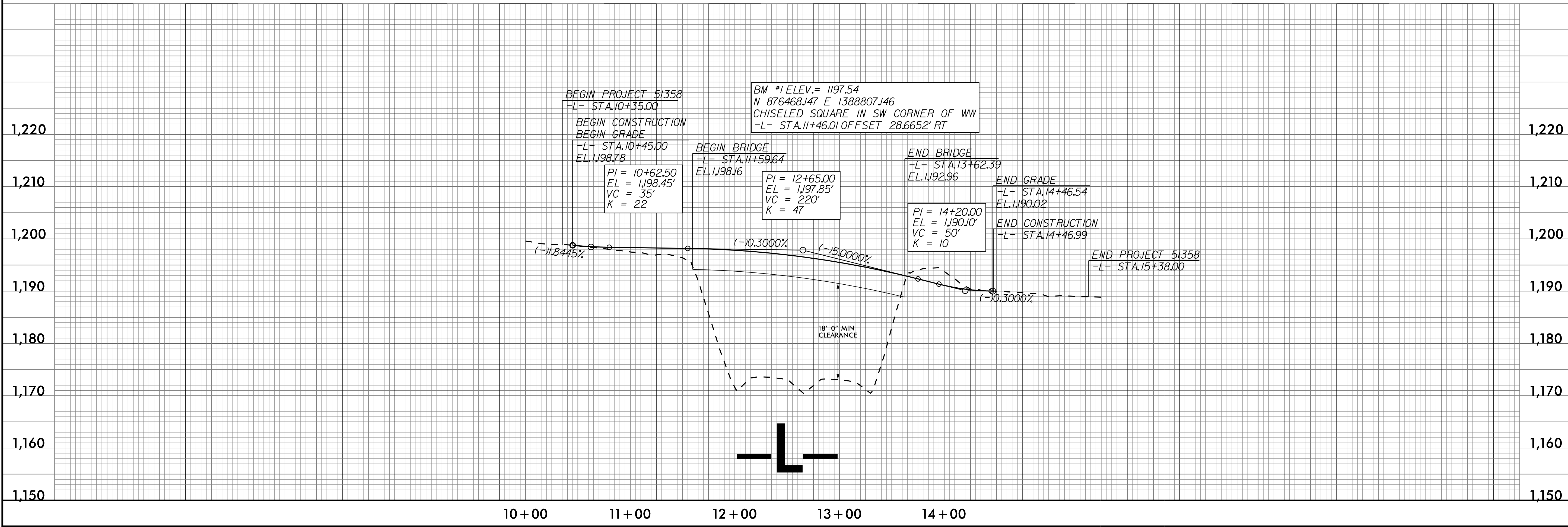
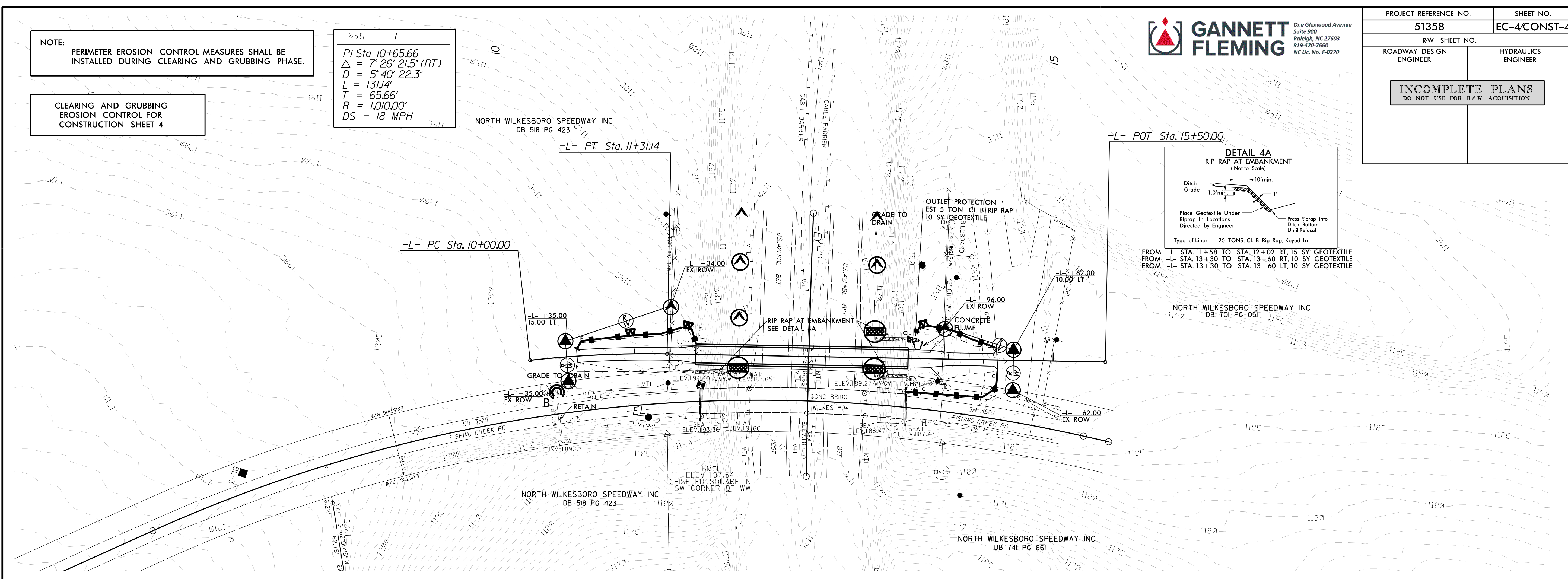

S:\SHERMAN\SSS 23 JUL 2004 12:33 p.m.\gfnr-pw\henlly.com\gfnr-pw-01\Documents\Projects\91725-Working\Task 020 - Wilkesboro Speedway Fed Bridge\Erosion Control\CADD\51358_EC_PSH_4_Final.dgn

6/23/16

0 2.5 5	PROJ. REFERENCE NO.	SHEET NO.
	51358	X-2

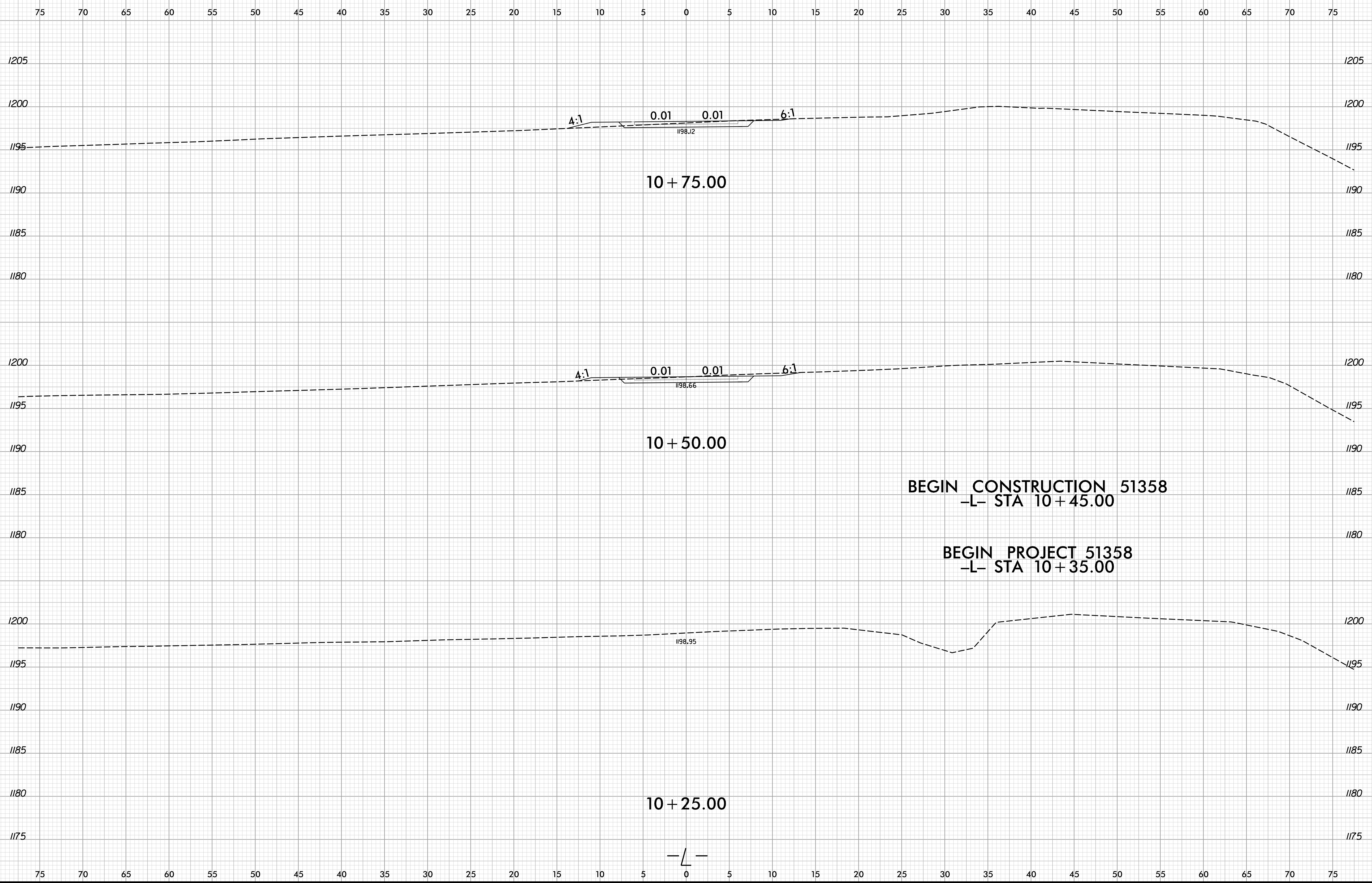

7/30/2024
\\X6C\51358_rdu_xp1.L.dgn
10:35:19 AM

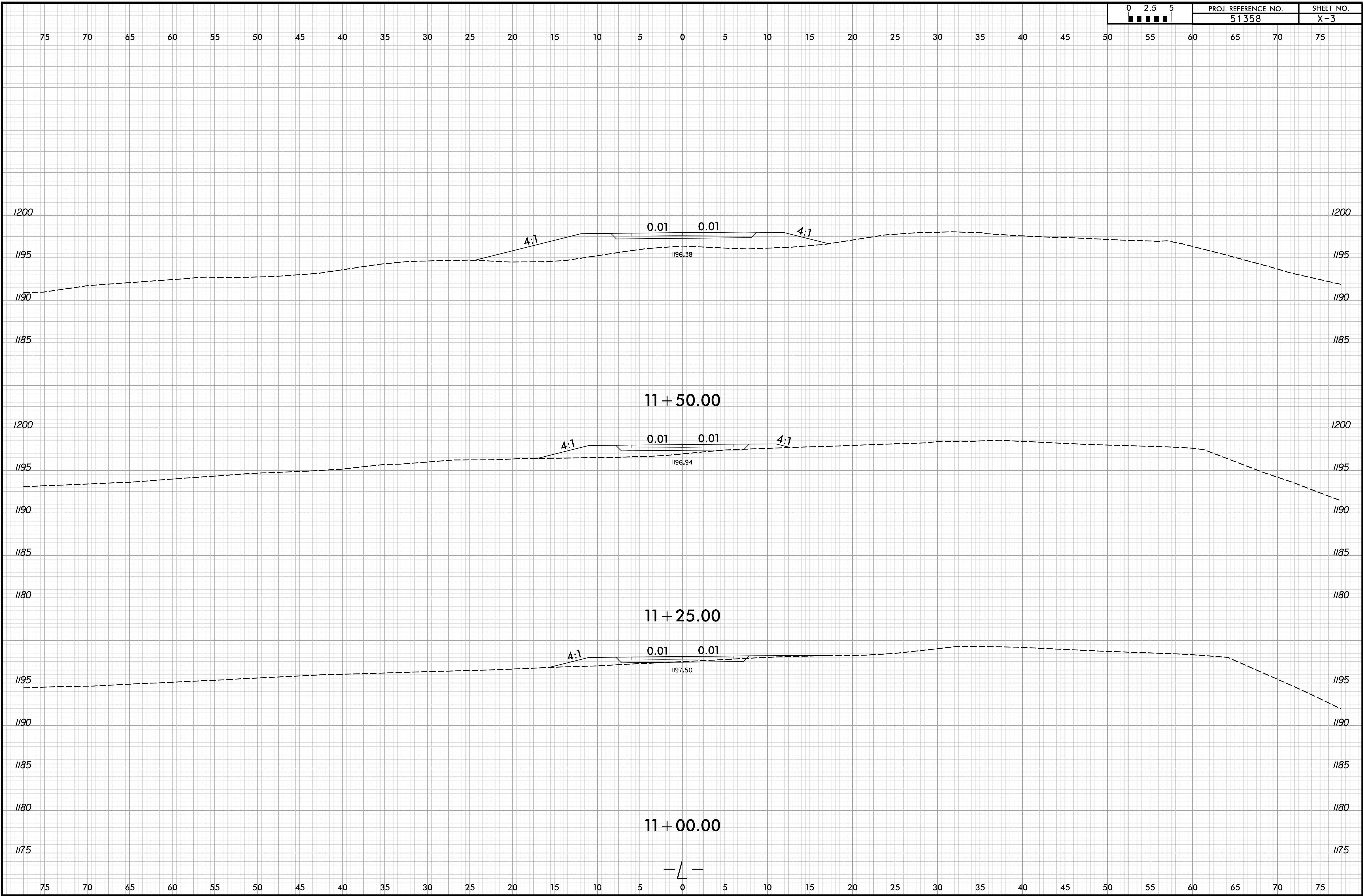

75 70 65 60 55 50 45 40 35 30 25 20 15 10 5 0 5 10 15 20 25 30 35 40 45 50 55 60 65 70 75

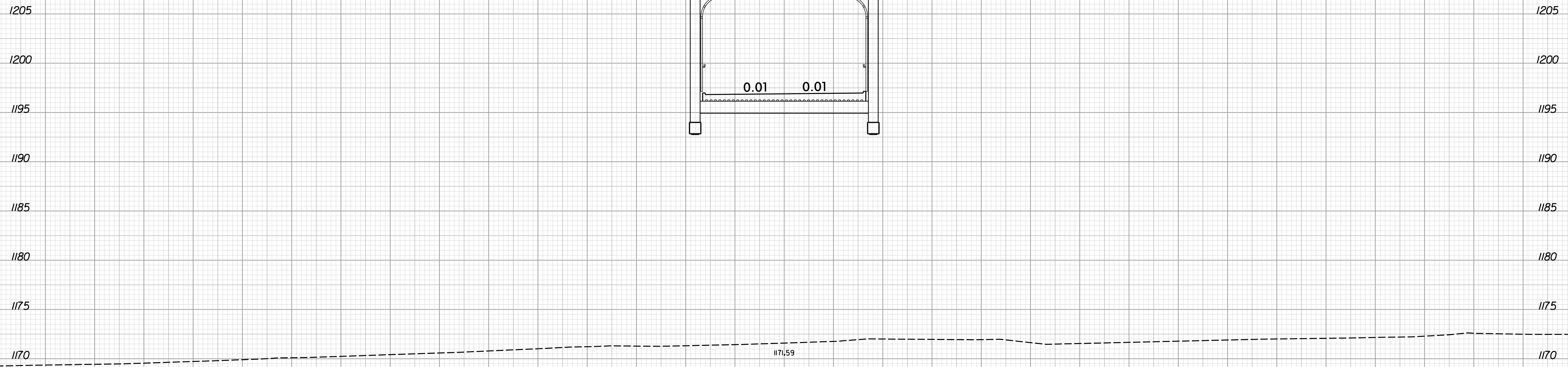

12 + 00.00

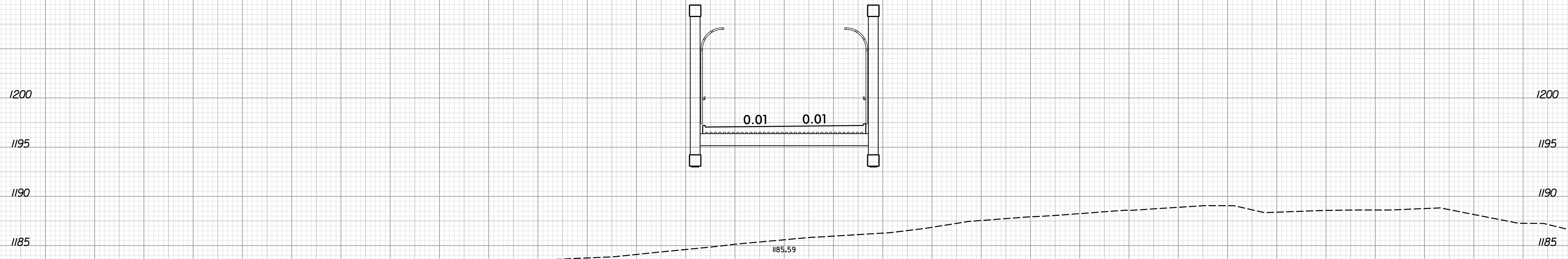

11 + 75.00

BEGIN BRIDGE
-L- STA 11 + 59.64

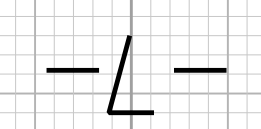

75 70 65 60 55 50 45 40 35 30 25 20 15 10 5 0 5 10 15 20 25 30 35 40 45 50 55 60 65 70 75

75 70 65 60 55 50 45 40 35 30 25 20 15 10 5 0 5 10 15 20 25 30 35 40 45 50 55 60 65 70 75

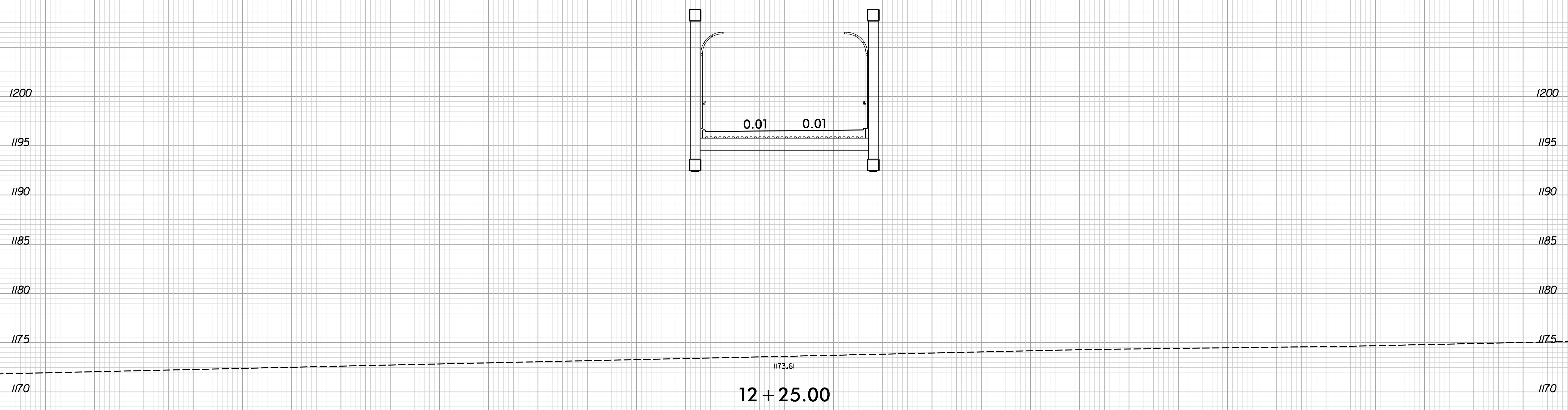
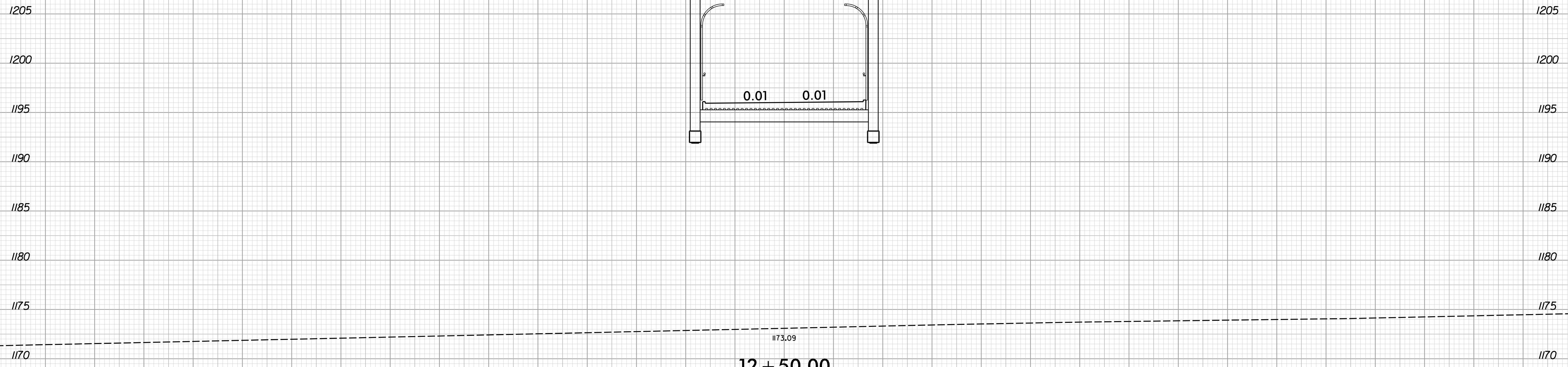

—/—

75 70 65 60 55 50 45 40 35 30 25 20 15 10 5 0 5 10 15 20 25 30 35 40 45 50 55 60 65 70 75

75 70 65 60 55 50 45 40 35 30 25 20 15 10 5 0 5 10 15 20 25 30 35 40 45 50 55 60 65 70 75

1200

1200

1195

1195

1190

1190

1185

1185

1180

1180

1175

1175

1170

1170

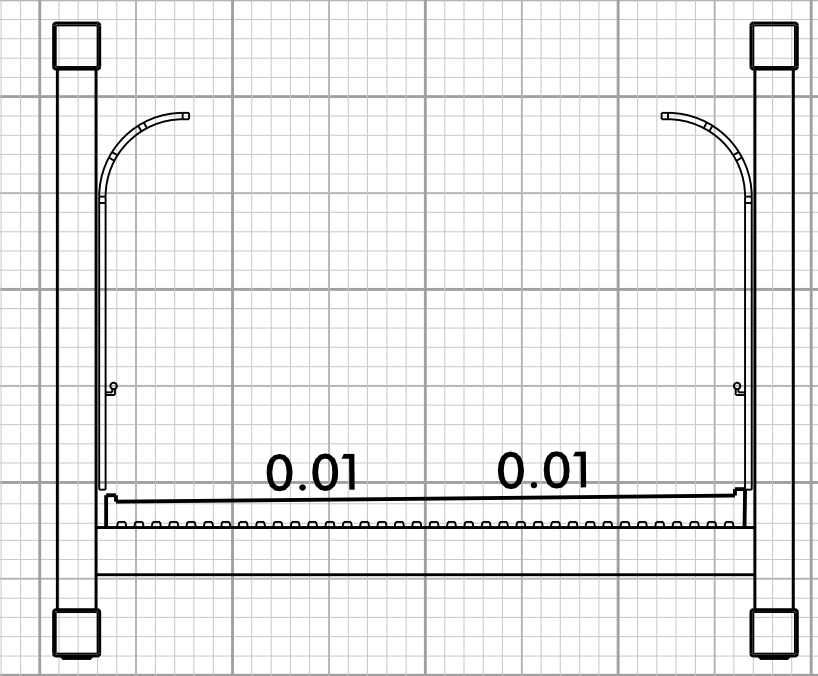

1173.08

13 + 00.00

1200

1200

1195

1195

1190

1190

1185

1185

1180

1180

1175

1175

1170

1170

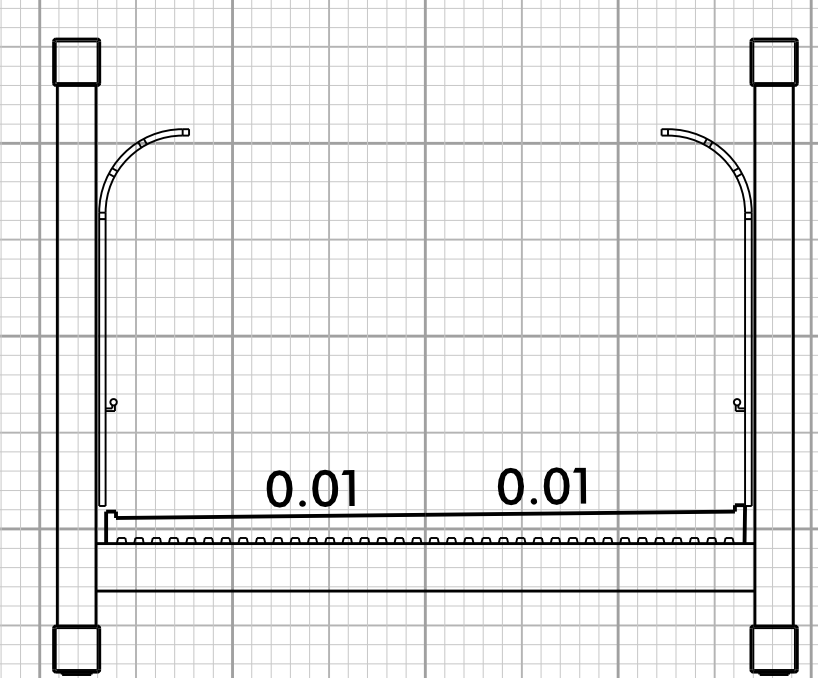

1171.93

12 + 75.00

1165

1165

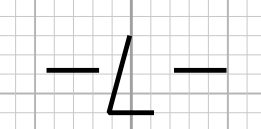

75 70 65 60 55 50 45 40 35 30 25 20 15 10 5 0 5 10 15 20 25 30 35 40 45 50 55 60 65 70 75

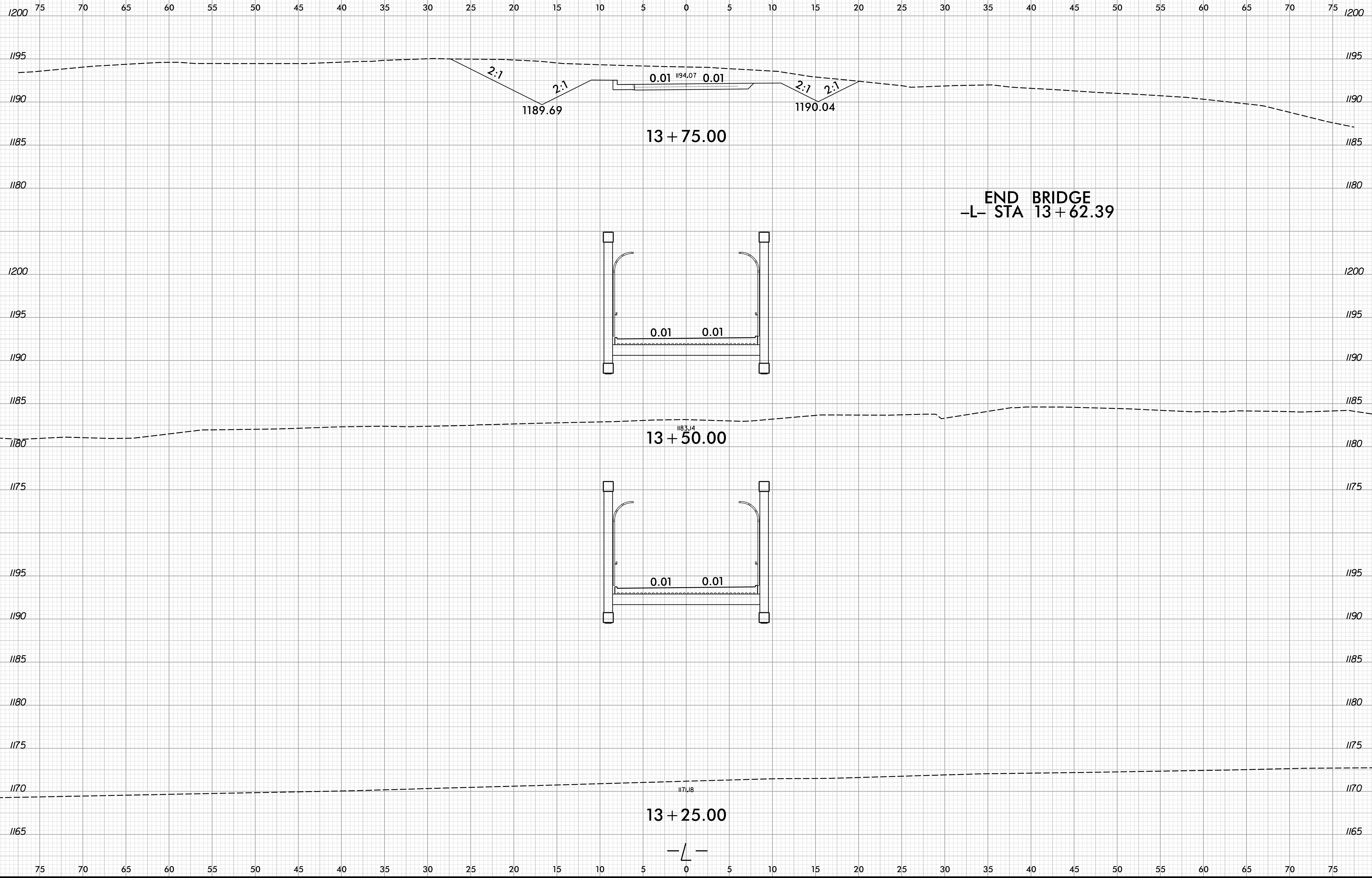

75 70 65 60 55 50 45 40 35 30 25 20 15 10 5 0 5 10 15 20 25 30 35 40 45 50 55 60 65 70 75

END PROJECT 51358
-L- STA 15+38.00

1195 1195

1190 1190

1185 1185

END CONSTRUCTION
-L- STA 14+46.99

1180 1180

14 + 50.00

1195 1195

1190 1190

1185 1185

1180 1180

14 + 25.00

1200 1200

1195 1195

1190 1190

1185 1185

1180 1180

1175 1175

14 + 00.00

1170 1170

75 70 65 60 55 50 45 40 35 30 25 20 15 10 5 0 5 10 15 20 25 30 35 40 45 50 55 60 65 70 75

